



# product catalogue

# About the company

## Safety, quality, trust

On the market since 1991.

## Success in expertise and skills

Konsmetal is a recognized European manufacturer of cash handling and mechanical security devices. The company's products are to be found in the President's Chancellery, the Polish Senate and even in the courts of European monarchs. They are widely used in the largest Polish and European banks, enterprises, national institutions, companies and private houses. We have gained the trust of 90% of Polish banks and financial institutions. The reliability of our products was confirmed when Konsmetal was awarded NATO's Commercial and Government Entity Code, constituting a distinguished mark in the NATO Codification System (NCS).

## Quality assurance policy

In 2010, Konsmetal, as the only company in Poland, became a member of the prestigious European Security Systems Association. ESSA is the leading certification services provider for security products – at European and international level.

## Certificates and approvals

Polish and foreign certificates and approvals guarantee the reliability of Konsmetal's products:

- IMP – Institute of Precision Mechanics (Poland);
- TÜV – TÜV NORD Polska – quality system certificate;
- ABW – ICT Security Department of the Internal Security Agency (Poland);
- NCAGE – NATO Commercial and Government Entity Code – a distinguished mark in the NATO Certification System;
- VdS Schadenverhütung (Germany);
- SBSC – Svensk Brand & Säkerhets Certifiering AB (Sweden);
- SP – Sveriges Provnings – och Forskningsinstitut (Sweden);
- SKAFOR – Dansk Forening for Skadeforsikring (Denmark);
- Hygienic approval – NIZP (National Institute of Public Health, Poland) – for storing goods in public utility buildings, such as educational and health care facilities; production plants, services and warehouses.

## Awards as confirmation of success

The unique position of Konsmetal's products is confirmed by numerous awards:

- European Medal for the Strong Safe with a Deposit Drum KP + WBX, awarded by the Committee for European Integration and Business Centre Club in 2001;



- › Gold Medal of the International Poznan Fair for Compact Deposit Drop Strong Safe KP 100 + WBN/N-VI, awarded at the International Security Devices Exhibition SECUREX 2003;
- › Gold Medal of the International Poznan Fair for Transfer Safe KP 80/5/EZ, awarded at the International Security Devices Exhibition SECUREX 2006;
- › Gold Medal of the International Poznan Fair for Dispenser, awarded on the International Security Devices Exhibition SECUREX 2008;
- › Gold Medal of the International Poznan Fair for Electronic Multi-safe XS, awarded at the International Security Devices Exhibition SECUREX 2008;
- › Two Acanthus Aureus statuettes awarded by the International Poznan Fair for a stand which was most coherent with the company's marketing strategies;
- › Medal for innovative technical solutions, awarded on the International Forum FINANCIAL UKRAINE 2008;
- › 'Gazeta Biznesu 2009' statuette awarded by the opinion making economy magazine 'Puls Biznesu' to dynamically developing Polish enterprises;
- › Gold Medal of the International Poznan Fair for Light KPL Strong Safe, awarded at the International Security Devices Exhibition SECUREX 2010;
- › Gold Medal of the International Poznan Fair for LS Safes, awarded at the International Security Devices Exhibition SECUREX 2010;
- › Gold Medal of the International Poznan Fair for Anti-burglary Self-Locking System, awarded at the International Security Devices Exhibition SECUREX 2012.

### Tradition and innovation

Konsmetal was established in 1991 and the development of the company continues by:

- › Conducting research and development works aimed at creating new, innovative products;
- › Training personnel, modernizing the company's organization with a customer-oriented approach;
- › Introducing modern company management systems;
- › Implementing cutting-edge technologies used only by leading trade companies in the world.



## Safes ..... 5

Your Safe Your Stronghold .....	6-7
Kolibri Safes .....	8-9
ML Furniture Safes .....	10-11
ML STRONG Furniture Safes .....	12-13
SL Light Safes .....	14-15
LS Safes .....	16-17
SG Office Safes .....	18-19
KSN Wall Safes .....	20
MLB Gun Safes.....	21
Accessories for the storage of firearms .....	22

## Strong Safes ..... 23

KP Strong Safes .....	24-27
Light KPL Strong Safes .....	28-32
KP VdS Strong Safes .....	33-34

## Cabinets ..... 35

Security Cabinets for Documents grade A, B, C.....	36-37
SD Security Cabinets grade S1, S2, 0.....	38-39
Security Cabinets for Documents grade A.....	40
Office Cabinets.....	41

## Deposit Drop Safes ... 42

Kolibri Deposit Drop Safes .....	43-44
ML Deposit Drop Safes .....	45-46
ML STRONG Deposit Drop Safes .....	47-48
SG Safes with a Deposit Drum .....	49
KP Strong Safes with Deposit Drum .....	50
SW Deposit Slot Cassettes .....	51

## Product for cashiers...52

LS+Teller Safes.....	53-54
Electronic Multi-safes XS.....	55-57
Transfer Safes .....	58-59

## Deposit Strong Safes.. 60

Electronic Deposit Strong Safes .....	61-62
Electronic Deposit Strong Safes with Online Booking .....	63-64

## Strongroom ..... 65

Strongroom .....	66
Cash Handling Center (CHC) .....	67

## Locks ..... 68

Locks .....	69
Safety for everyone .....	70
How to select a Safe .....	71





Safes

# Your Safe your Stronghold

> Konsmetal Safes pass demanding burglary resistance testing and have certificates of conformity with the most restrictive European standards.

> Tests are conducted by a third-party certifier. In order to be granted a certificate, a Safe's resistance to various burglary methods must be proven. When a Safe finally passes the tests, it is given a certificate in an appropriate resistance grade. The higher the security level, the more valuable items may be stored in a Safe.

Certificates of individual resistance grades are granted according to the following standards:

> European standard EN 1143-1: guarantees burglary protection of valuable property in resistance grades of zero and higher.

> European standard EN 1143-2: guarantees burglary protection of valuable property for day and night deposit systems in resistance grades of zero and higher.

> European standard EN 14450: covers certification in security grades S1 and S2.

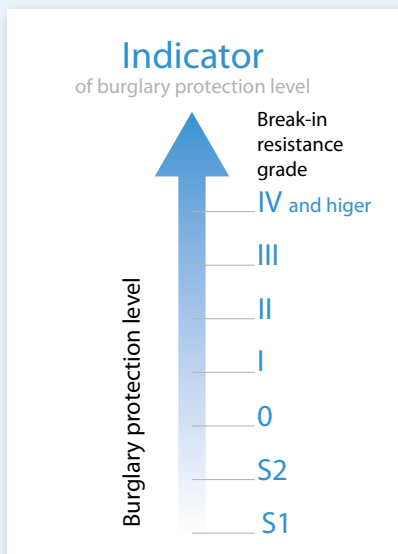

## Guarantee of burglary resistance

Konsmetal Safes fulfill the most restrictive European standards of burglary resistance.



## High quality guarantee

The Konsmetal brand stands for high quality of manufacturing and top-quality products. Our Clients can therefore be certain that every product leaving our plant meets all the requirements regarding the expected functional properties and safety for their users.



## Maintenance

Konsmetal's business philosophy is based on building trust and long-term relations with our Clients. To ensure the comfort of using our products, we have established an extensive technical service and maintenance network, offering a wide range of services – from assembly to maintenance operations.



## Made in Europe

Konsmetal products are manufactured in the EU.

# Your Safe your Stronghold\*



## Certified locks

Konsmetal Safes are equipped with certified locks of the highest quality, manufactured by renowned companies. Those include key, combination and electronic locks of different grades.

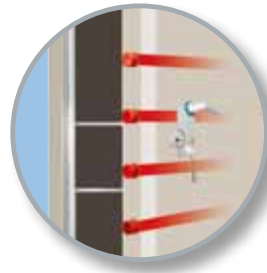

## Highest security standards

Konsmetal Safes are equipped with complex door blocking mechanisms using movable and fixed bolts. Bolts prevent the Safe from being opened during attempts of breaking the lock. Special shielding systems provide additional bolts' protection against drilling and breaking.



## Interior equipment customization

Our Safes can be equipped with additional equipment, e.g.: separately lockable internal boxes, drop deposit slot systems, alarm systems and shelves.

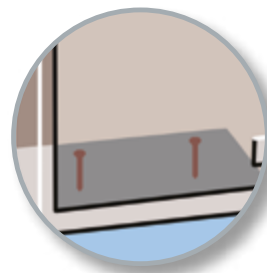

## Floor mounting

Our devices are suitable for floor mounting in accordance with the European standard guidelines.

\* Level of used security devices depends on the product's grade.

# OPTIMUM SECURITY

## AT UNBEATABLE PRICES



### > Certificates for storing:

- > Valuables in accordance with the PN-EN 14450:2006 standard, grade S1.
- > Firearms and ammunition:
  - > in accordance with the requirements of KT/101/IMP/2008;
  - > compliant with the requirements of the Regulation of the Minister of Internal Affairs and Administration of 03.04.2000 on the storage, carrying and keeping records of weapons and ammunition.

### > Product description:

- > The Koliber series includes modern Safes for home and office use.
- > Suitable for depositing cash, stocks, shares, documents, jewelry, firearms, ammunition, etc.
- > 'Laptop' versions are recommended for storing portable computers.
- > Koliber Safes are designed for furniture installation and can also be used as free-standing safes after mounting to the floor.

- > Available in wall-mounted version (page 20).
- > Equipped with shelves of adjustable height (depending on the selected model).
- > The body of the Safe is made of a 3 mm-thick, high-quality steel with high resistance to attack.
- > Reinforced door panel including an additional cover of the bolt mechanism and lock.
- > Models with electronic locks are additionally equipped with a handle.
- > Robust bolts with a diameter of 20 mm.
- > Bolts are protected against drilling.
- > Interior and exterior door blockade preventing opening of the Safe after cutting out hinges.
- > 24-month warranty.

### > Additional equipment

(available depending on the model):

- > Additional shelf with adjustable height.
- > Handgun holders.
- > Drop deposit slot or drop deposit drawer.
- > Electronic or combination lock.
- > Two mounting anchors.



## Technical data of Koliber Safes grade S1

Model	External dimensions [mm]			Internal dimensions [mm]			Weight [kg]	Volume [l]
	height	width	depth	height	width	depth		
Koliber 16	160	310	180	154	304	130	10	6
Koliber 20	200	310	200	194	304	150	12	9
Koliber 35	350	310	280	344	304	230	19	23
Koliber 45 Laptop 15"	450	400	370	444	394	320	35	56
Koliber 62 Laptop 15"	620	400	370	614	394	320	41	77
Koliber 20 Laptop 17"	200	490	370	194	484	320	21	31
Koliber 45 Laptop 17"	450	490	370	444	484	320	38	69
Koliber 62 Laptop 17"	620	490	370	614	484	320	51	96

Product weight is specified for reference only and is subject to change.

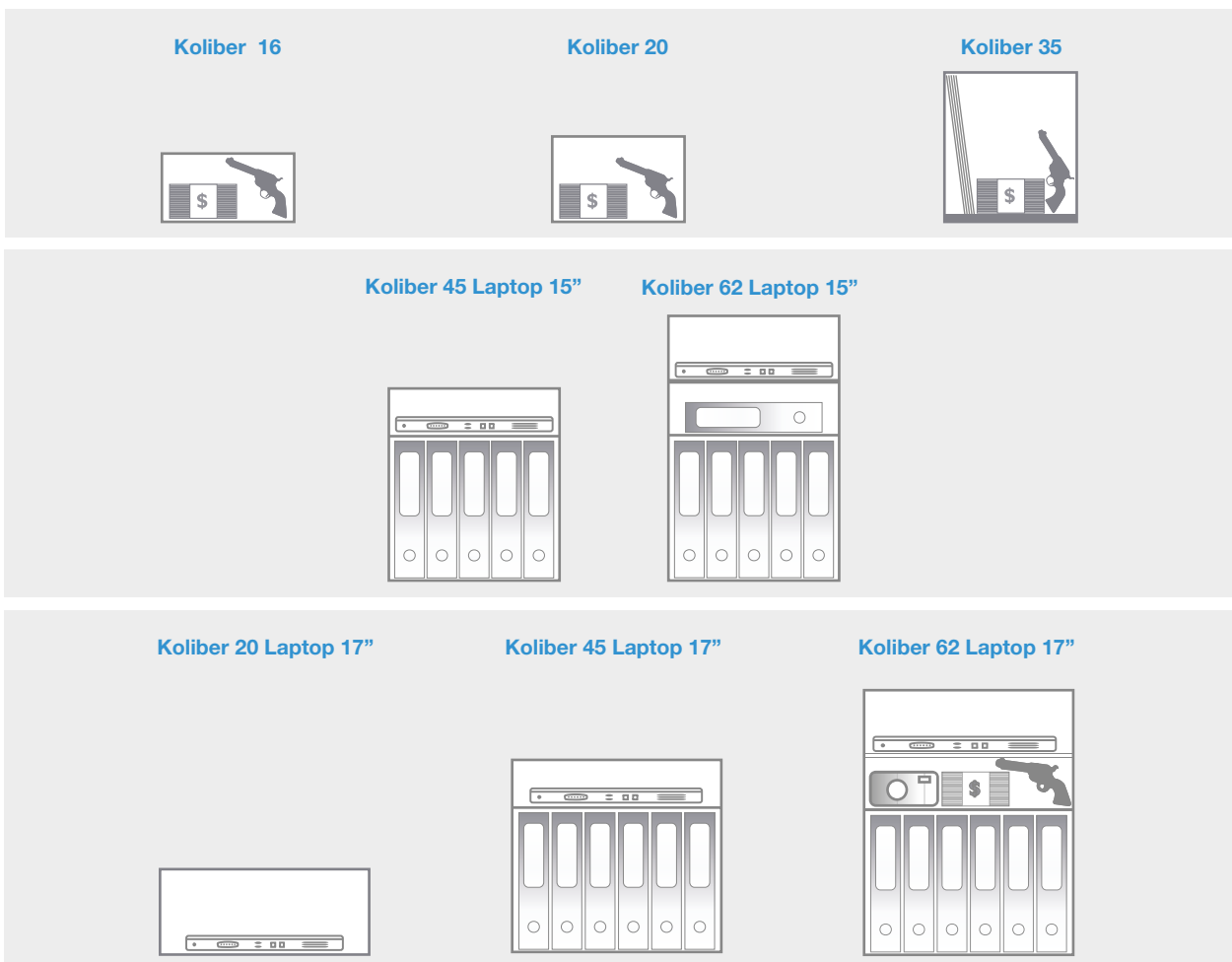

## Volume



### > Types of locks:



### > Standard colours:

-  light grey RAL 9002
-  light grey RAL 7035
-  black RAL 9005

## RELIABILITY AND FUNCTIONALITY



### > Certificates for storing:

- > Valuables in accordance with the PN-EN 14450:2006 standard, grade S1.
- > Classified documents TYPE 2 in accordance with the Regulation of the Council of Ministers of 29 May 2012 on the physical security measures used to protect classified information.
- > Firearms and ammunition:
  - > in accordance with the requirements of KT/101/IMP/2004;
  - > compliant with the requirements of the Regulation of the Minister of Internal Affairs and Administration of 03.04.2000 on the storage, carrying and keeping records of weapons and ammunition.

### > Product description:

- > For home and office use.
- > Patented anti-burglary construction with an anti-burglary frame.
- > Small weight enables installation in virtually any room or piece of furniture.

- > Minimalist, elegant design makes it easy to integrate the Safe in interiors of any style.
- > Wide range of sizes.
- > Models with electronic locks are also equipped with a handle and additional bolts on top and bottom.
- > Equipped with shelves with height adjustment (depending on the model).
- > Suitable for floor mounting.
- > 24-month warranty.

### > Additional equipment

(available depending on the model):

- > Separately lockable internal box.
- > Additional shelf with height adjustment.
- > Handgun holders.
- > Drop deposit drawer and a drop deposit slot.
- > Certified locks: key, electronic.
- > Alarm installation output.
- > Protective sealing.
- > Mounting anchor.

## How does the Anti-burglar Frame work?

The connection between door and body is the area of the Safe usually attacked by a burglar first.

Our anti-burglar frame armors the body, significantly increasing its impact resistance and resistance to crowbar attacks.

In consequence, the body has virtually no weak points.

The frame provides an exceptionally sturdy bolt protection and effectively secures them against drilling.

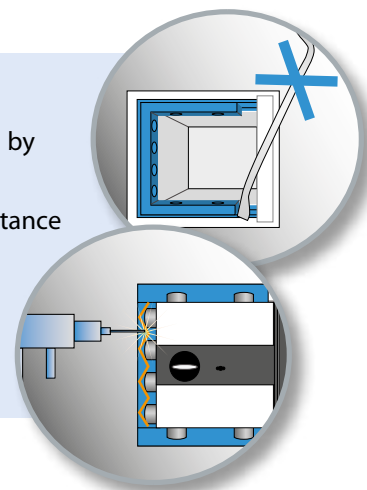

## Technical data of ML Furniture Safes grade S1

Model	External dimensions [mm]			Internal dimensions [mm]			Weight [kg]	Volume [l]
	height	width	depth	height	width	depth		
ML 30	300	400	410	292	379	327	30	36
ML 45	450	400	440	442	379	357	41	60
ML 67	670	400	440	662	379	357	56	90
ML 85	850	490	440	842	469	357	70	141
ML 100	1000	490	440	992	469	357	84	166

Product weight is specified for reference only and is subject to change.

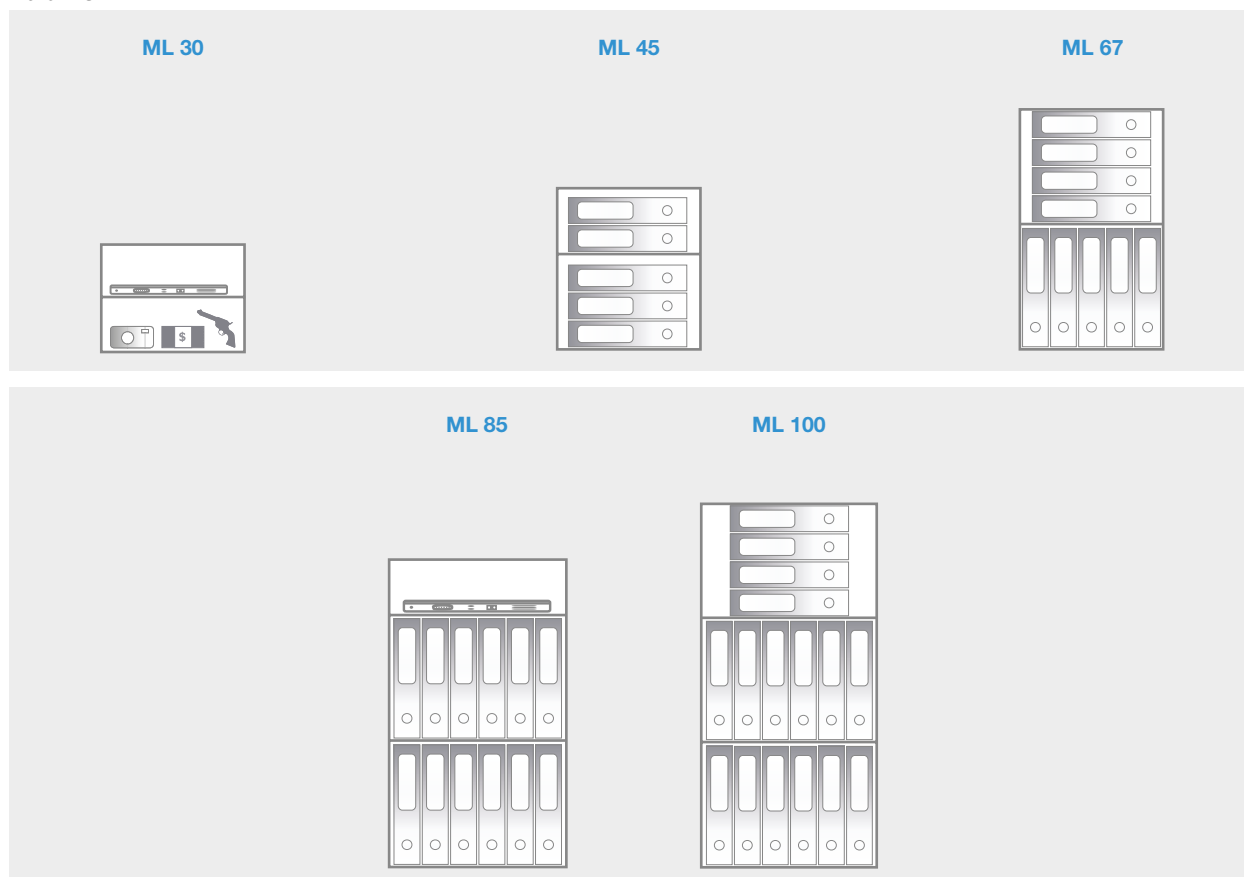

## Volume



### >Types of locks:



### >Standard colours:

-  light grey RAL 7035
-  black RAL 9005

# ROBUST

## AND RELIABLE DESIGN



### > Certificates for storing:

- > Valuables in accordance with the PN-EN 14450:2006 standard, grade S2.
- > Classified documents TYPE 3 in accordance with the Regulation of the Council of Ministers of 29 May 2012 on the physical security measures used to protect classified information.
- > Firearms and ammunition:
  - > in accordance with the requirements of KT/101/IMP/2008;
  - > compliant with the requirements of the Regulation of the Minister of Internal Affairs and Administration of 03.04.2000 on the storage, carrying and keeping records of weapons and ammunition.

### > Product description:

- > ML STRONG Furniture Safes are designed for storing documents, jewelry, guns and ammunition, firearms accessories and other important and valuable items.

- > Double wall steel structure with high resistance against attack.
- > Reinforced door design.
- > Powerful door bolting system.
- > Small weight enables installation in practically any room or piece of furniture.
- > Ergonomic handle.
- > 24-month warranty.

### > Additional equipment:

- > Separately lockable internal box.
- > Additional shelf with height adjustment.
- > Handgun holders.
- > Drop deposit drawer and a drop deposit slot.
- > Certified locks: key, combination, electronic.
- > Time delay and silent alarm of the lock.
- > Alarm installation output.
- > Protective sealing.
- > Mounting anchor.

# ML STRONG Furniture Safes grade S2

## Robust design

Reinforced safe structure, featuring:

- > Body made of a sturdy metal plate;
- > Double-layered structure with high resistance against attack;
- > Front door panel made of a strong metal sheet.



## Anti-burglary Self Locking System

Burglar resistant safe door:

- > A unique Anti-burglary Self Locking System significantly increases the Safe's resistance to attack by hammer or crowbar.
- > Additional cover of the door bolt system.

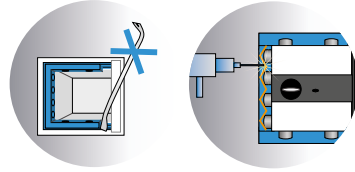

## Bolts of a diameter of 30 mm

The system of reinforced vertical and horizontal bolts prevents the Safe's door from breaking.



## Handle

All ML STRONG models are equipped with a handle, thus safe operating is easier and more convenient.



Technical data of ML STRONG Furniture Safes grade S2



Model	External dimensions [mm]			Internal dimensions [mm]			Weight [kg]	Volume [l]
	height	width	depth	height	width	depth		
ML STRONG 30	300	400	410	200	298	286	40	17
ML STRONG 45	450	400	440	350	298	316	56	33
ML STRONG 67	670	400	440	570	298	316	73	54
ML STRONG 85	850	490	440	750	388	316	96	92
ML STRONG 100	1000	490	440	900	388	316	110	110

Product weight is specified for reference only and is subject to change.

Volume

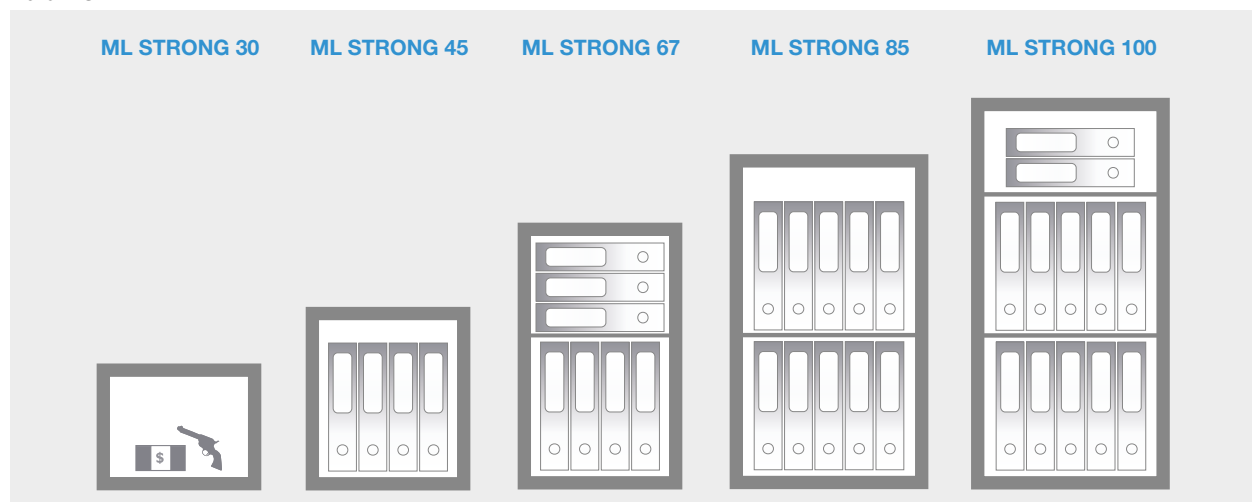

> Types of locks:



> Standard colours:

- light grey RAL 7035
- black RAL 9005

# RELIABLE SECURITY SOLUTIONS



#### > Certificates for storing:

- > Valuables in accordance with the PN-EN 1143-1+A1:2009 standard, grade I (model SL 26).
- > Valuables in accordance with the PN-EN 1143-1 + A1:2012 standard, grade I (model SL 45, SL 67, SL 100, SL 120, SL 150).
- > Firearms and ammunition:
  - > in accordance with the requirements of KT/101/IMP/2008;
  - > compliant with the requirements of the Regulation of the Minister of Internal Affairs and Administration of 03.04.2000 on the storage, carrying and keeping records of weapons and ammunition.

#### > Product description:

- > A complex body and door structure made of top-quality steel plate with high impact resistance.
- > Mobile vertical and horizontal bolting system.
- > Fixed bolts making it impossible to tear doors out even after cutting out or destroying hinges.

- > Top-quality mechanisms blocking door opening during attempts to break the lock.
- > Equipped with shelves with height adjustment (depending on the model).
- > Suitable for floor mounting.
- > 24-month warranty.

#### > Additional equipment

(available depending on the model):

- > Separately lockable internal box (SMART internal box).
- > Additional shelf with height adjustment.
- > Handgun holders.
- > Certified locks: key, combination or electronic.
- > Time delay and silent alarm of the lock.
- > Alarm installation output.
- > Protective sealing.
- > Two mounting anchors.

## Technical data of SL Light Safes grade I

Model	External dimensions [mm]			Internal dimensions [mm]			Weight [kg]	Volume [l]
	height	width	depth	height	width	depth		
SL 26	260	410	340	150	220	205	45	9
SL 45	450	490	440	348	388	295	80	40
SL 67	670	490	440	568	388	295	109	65
SL 100	1000	490	440	898	388	295	140	103
SL 120	1200	490	440	1098	388	295	179	126
SL 150	1500	490	440	1398	388	295	215	160

Product weight is specified for reference only and is subject to change.



## Volume



### > Types of locks:



### > Standard colours:

-  light grey RAL 9002
-  light grey RAL 7035
-  black RAL 9005

# LS Safes grade I



## > Certificates for storing:

- > Valuables in accordance with the PN-EN 1143-1:2012 standard, grade I.
- > Firearms and ammunition:
  - > in accordance with the requirements of KT/101/IMP/2008;
  - > compliant with the requirements of the Regulation of the Minister of Internal Affairs and Administration of 03.04.2000 on the storage, carrying and keeping records of weapons and ammunition.

## > Product description:

- > Patented anti-burglary construction.
- > Boltwork system with robust horizontal bolts.
- > Additional upper and lower vertical bolts.
- > A fixed bolt blocks access to the Safe even after cutting out hinges.
- > Massive door protected with several layers of a steel-composite armor.
- > Increased protection of bolts and the lock.
- > Thanks to the unique construction, the door opening angle is 180 degrees, facilitating very convenient access to the Safe's interior.
- > 24-month warranty.

The LS Safe body is filled with a special ThermControl® composite. The innovative ThermControl® formula prevents the material from heating in cases of fire and exposure to high temperatures.

**ThermControl®**

Laser technology manufacturing provides extraordinary precision of workmanship and superb reliability.

**Laser  
technology**

## > Types of locks:



## > Standard colours:

- light grey RAL 9002
- light grey RAL 7035
- black RAL 9005



**Anti-burglary Self Locking System** is a worldwide innovative solution ensuring a considerably more reliable protection against breaking into the Safe in comparison with traditional systems.

The connection between door and body is the area of the Safe usually attacked first by burglars. A burglar uses a crowbar as a lever, trying to bend the body or the door to reach inside the Safe. Our patented Anti-burglar Frame armors the body, significantly increasing its resistance to impacts and crowbar attacks. In consequence, the body has virtually no weak points.

Another frequent burglary method is attempting to take out the door and reach inside the Safe. The unique Anti-burglary Self Locking System, as the only one on the market, effectively prevents such attempts.

The solution was awarded with the Gold Medal of the SECUREX 2012 Poznan International Fair.

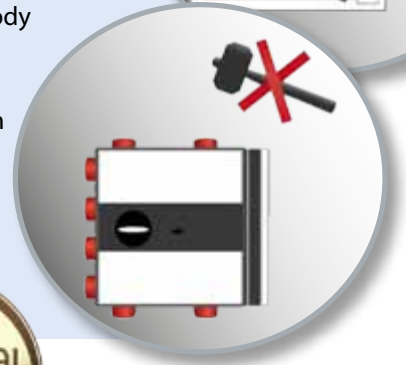
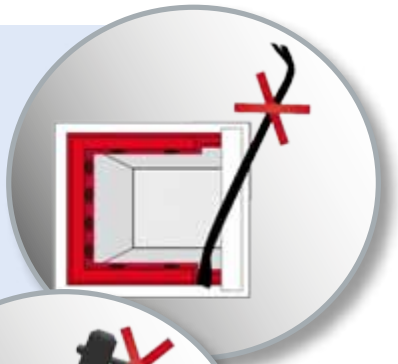

## > Additional equipment

(available depending on the model):

- > Separately lockable internal box (SMART internal box).
- > Additional shelf with height adjustment.
- > Handguns holders.
- > Certified locks: key, combination or electronic.
- > Time delay and silent alarm of the lock.
- > Alarm installation output.
- > Protective sealing.
- > Two mounting anchors.

Technical data of LS Safes grade I 

Model	External dimensions [mm]			Internal dimensions [mm]			Weight [kg]	Volume [l]
	height	width	depth	height	width	depth		
LS 45	450	490	440	348	388	295	80	40
LS 67	670	490	440	568	388	295	108	65

Product weight is specified for reference only and is subject to change.

## Volume

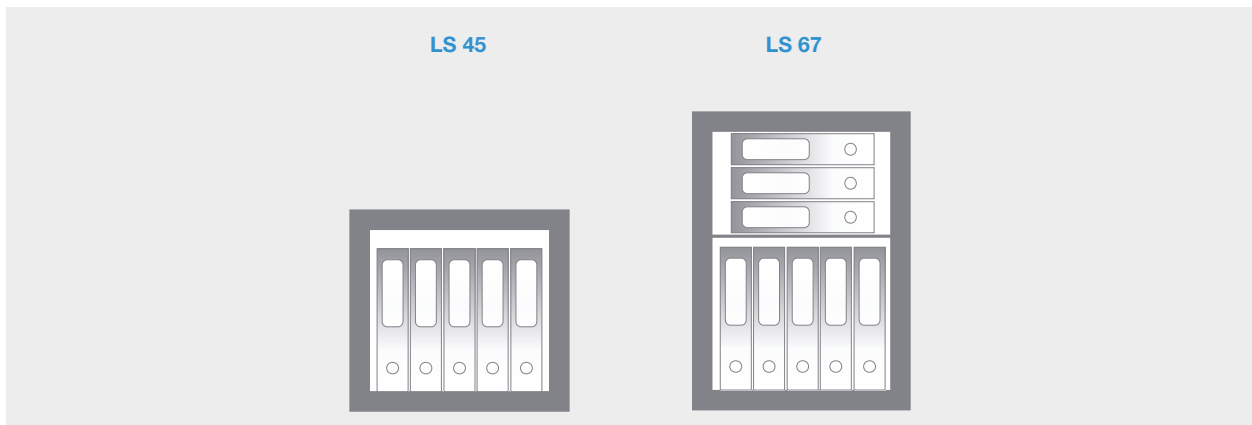

# HIGH LEVEL OF PROTECTION



#### > Certificates for storing:

- > Valuables in accordance with the PN-EN 1143-1+A1:2009 standard, grade II.

#### > Product description:

- > High burglary resistance combined with exceptional elegance.
- > Manufactured with a multi-layer structure to the body and door filled with a special composite.
- > Complex bolting system blocking the opening of doors during burglary attempts.
- > Fixed bolt making it impossible to take doors out even after cutting out or destroying hinges.
- > Top-quality mechanisms that block door opening during attempts to break the lock.

- > Shelves with height adjustment.

- > Suitable for floor mounting.

- > 24-month warranty.

#### > Additional equipment

(available depending on the model):

- > Separately lockable internal box.
- > Additional shelf with height adjustment.
- > Deposit drum (WBX – page 49).
- > Drop deposit slot.
- > Certified locks: key, combination, electronic.
- > Alarm sensors: shock, bolt and door position sensors.
- > Time delay and silent alarm of the lock.
- > Alarm installation output.
- > Two mounting anchors.

## Technical data of SG Office Safes grade II



Model	External dimensions [mm]			Internal dimensions [mm]			Weight [kg]	Volume [l]
	height	width	depth	height	width	depth		
SG 70	700	480	480	545	360	300	114	59
SG 100	1000	510	480	845	390	300	157	99
SG 120	1200	510	480	1045	390	300	185	122
SGP 180	1800	730	730	1645	610	550	447	552

Product weight is specified for reference only and is subject to change.

## Volume



### > Types of locks:



### > Standard colours:

- light grey RAL 9002
- light grey RAL 7035
- black RAL 9005

## DISCRETE PROTECTION

### – FOR YOUR EYES ONLY



#### > Certificates for storing:

- > Valuables in accordance with the PN-EN 14450:2006 standard, grade S1.
- > Firearms and ammunition:
  - > in accordance with the requirements of KT/101/IMP/2008;
  - > compliant with the requirements of the Regulation of the Minister of Internal Affairs and Administration of 03.04.2000 on the storage, carrying and keeping records of weapons and ammunition.

#### > Product description:

- > Suitable for wall mounting.
- > Flat door and escutcheon plate make hiding the built-in Safe easy, for example behind a painting.
- > Equipped with shelves with height adjustment (depending on the model).
- > 24-month warranty.

#### > Additional equipment

(available depending on the model):

- > Additional shelf with height adjustment.
- > Certified locks: key, combination or electronic.

#### > Types of locks:



#### > Standard colours:

- light grey RAL 9002
- light grey RAL 7035
- black RAL 9005

#### Technical data of KSN Wall Safes grade S1

Model	External dimensions [mm]			Internal dimensions [mm]			Weight [kg]	Volume [l]
	height	width	depth	height	width	depth		
KSN Wall Safe 16	234	384	194	154	304	130	10	6
KSN Wall Safe 20	274	384	194	194	304	130	13	8
KSN Wall Safe 35	424	384	194	344	304	130	16	14
KSN Wall Safe 20 Laptop 17"	274	564	384	194	494	320	17	31
KSN Wall Safe 45 Laptop 17"	524	564	384	444	490	320	33	70

Product weight is specified for reference only and is subject to change.

#### Volume

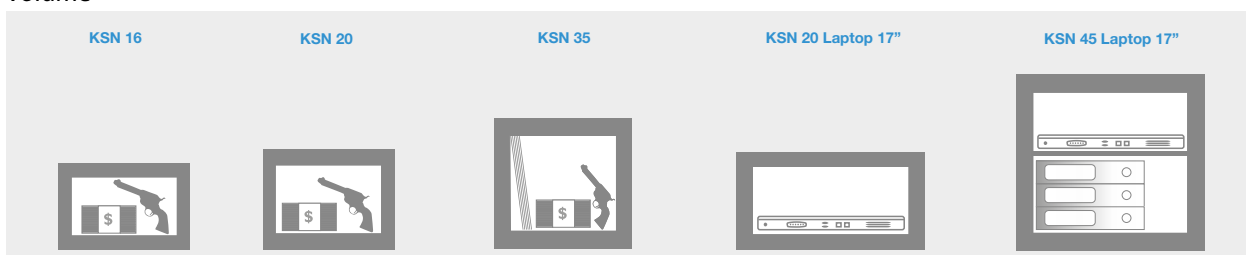

# PROTECT YOUR WEAPONS

## FROM FALLING INTO THE WRONG HANDS



### > Certificates for storing:

- > Valuables in accordance with the PN-EN 14450:2006 standard, grade S1.
- > Firearms and ammunition:
  - > in accordance with the requirements of KT/101/IMP/2004;
  - > compliant with the requirements of the Regulation of the Minister of Internal Affairs and Administration of 03.04.2000 on the storage, carrying and keeping records of weapons and ammunition.

### > Product description:

- > MLB Gun Safes are mainly used to store long guns and related accessories.
- > Equipped with ammunition containers and cleaning rod holders, as well as:
  - > MLB 150/4 – 4 gun holders, shelf (this model is not equipped with a door handle);
  - > MLB 150/5 – 5 gun holders, a lockable internal box;
  - > MLB 150S/8 – 8 gun holders, a lockable internal box;
  - > MLB150S/5 – 5 gun holders, a lockable internal box, a special shelf arrangement and 6 accessory containers on the door;

- > MLB 150D/11 – 11 gun holders, a lockable internal box;
- > MLB 150D/8 – 8 gun holders, a lockable internal box, a special shelf arrangement and 6 accessory containers on the door.
- > Solid steel body and door ensuring high resistance to attack.
- > Equipped with a certified lock: key, combination or electronic.
- > Suitable for floor mounting.
- > 24-month warranty.

### > Additional equipment:

- > Additional lock: key, combination or electronic.
- > Time delay and silent alarm of the lock.
- > Alarm installation output.
- > Two mounting anchors.

### > Types of locks:



### > Standard colours:

- light grey RAL 9002
- light grey RAL 7035
- black RAL 9005

### Technical data of MLB Gun Safes grade S1

Model	External dimensions [mm]			Internal dimensions [mm]			Weight [kg]	Volume [l]
	height	width	depth	height	width	depth		
MLB 150/4	1500	300	350	1490	280	260	83	108
MLB 150/5	1500	400	440	1490	380	350	101	198
MLB 150S/8	1500	600	440	1490	580	350	123	302
MLB 150S/5	1500	600	440	1490	580	350	146	302
MLB 150D/11	1500	800	440	1490	780	350	153	407
MLB 150D/8	1500	800	440	1490	780	350	170	407

Product weight is specified for reference only and is subject to change.





# Accessories for the storage of firearms

The following KONSMETAL products are intended for handgun storage:

- > Koliber Safes, grade S1;
- > ML Furniture Safes, grade S1;
- > ML STRONG Furniture Safes, grade S2;
- > SL Light Safes, grade I;
- > LS Safes, grade I;
- > KSN Wall Safes, grade S1;
- > KP Strong Safes, grade II-VI and VIII;
- > Light KPL Strong Safes, grade III and VI.

Number of handgun holders:

MODEL	GRADE	NUMBER OF HANDGUN HOLDERS
Koliber Safes	S1	5 or 6
ML Furniture Safes	S1	5 or 6
ML STRONG Furniture Safes	S2	5 or 6
SL Light Safes	I	5
LS Safes	I	5
KSN Wall Safes	S1	5

ACCESSORIES	PRODUCTS COMPATIBLE WITH THE ACCESSORY	DESCRIPTION	IMAGE
<b>Interior accessories</b>			
Shelf with handgun holders	<ul style="list-style-type: none"> <li>• Koliber Safes, grade S1;</li> <li>• ML Furniture Safes, grade S1;</li> <li>• ML STRONG Furniture Safes, grade S2;</li> <li>• LS Safes, grade I;</li> <li>• SL Light Safes, grade I;</li> <li>• KSN Wall Safes, grade S1.</li> </ul>	For a comfortable and safe handgun storage. Recommended for all handgun owners.	
Separately lockable internal box	<ul style="list-style-type: none"> <li>• ML Furniture Safes, grade S1;</li> <li>• ML STRONG Furniture Safes, grade S2;</li> <li>• LS Safes, grade I;</li> <li>• SL Light Safes, grade I;</li> <li>• SG Office Safes, grade II;</li> <li>• KP Strong Safes, grade II-VI and VIII;</li> <li>• Light KPL Strong Safes, grade III and VI.</li> </ul>	For safeguarding weapons with ammunition and all additional equipment and protecting them against falling into the wrong hands. The separately lockable internal box is especially recommended when more than one person has access to the Safe.	
<b>Additional safety elements</b>			
Protective sealing	<ul style="list-style-type: none"> <li>• ML Furniture Safes, grade S1;</li> <li>• ML STRONG Furniture Safes, grade S2;</li> <li>• LS Safes, grade I.</li> <li>• SL Light Safes, grade I;</li> <li>• Light KPL Strong Safes, grade III and VI;</li> <li>• KP Strong Safes, grade II- VI and VIII.</li> </ul>	Allows for controlling whether the product (in which the weapon is stored) was opened by unauthorized persons. Protective sealing is particularly recommended when more than one person has access to the Safe, especially when storing extremely vulnerable items or documents.	
Alarm sensors: shock sensor, door position sensor and bolts position sensor	<ul style="list-style-type: none"> <li>• ML Furniture Safes, grade S1;</li> <li>• ML STRONG Furniture Safes, grade S2;</li> <li>• LS Safes, grade I;</li> <li>• SL Light Safes, grade I;</li> <li>• SG Office Safes, grade II;</li> <li>• Light KPL Strong Safes, grade III and VI;</li> <li>• KP Strong Safes, grade II-VI and VIII.</li> </ul>	Provide anti-burglary protection for the product. Immediately signal a potential attempt to break into the Safe. Alarm sensors are especially recommended for rooms without a comprehensive anti-burglary system.	



Strong Safes

## KP Strong Safes grade II-VI, VIII



### > Certificates for storing:

- > Valuables in accordance with the PN-EN 1143-1+A1:2009 standard, grade II-VI, VIII.

### > Product description:

- > Highest level of anti-burglary protection thanks to a multi-layered steel structure of the body and door filled with a special composite.
- > Complex bolting system: horizontal and vertical bolts and a fixed bolt.
- > Equipped with certified locks:
  - > Grade-A key lock (models in grade II);
  - > Grade-B key lock (models in grade III);
  - > Grade-B key lock and grade-B combination lock (models in grade IV-V);
  - > Grade-C key lock and grade-C combination lock (models in grade VI and VIII).
- > Optional mounting of any two locks.
- > Door opening angle of 200 degrees.
- > 24-month warranty.

### > Additional equipment

(available depending on the model):

- > Separately lockable internal box.
- > Additional shelf with height adjustment.
- > Sliding shelf (in grade II).
- > Certified locks: key, combination, electronic.
- > Alarm sensors: shock, bolt and door position sensors.
- > Time delay and silent alarm of the lock.
- > Alarm installation output.
- > Protective sealing.
- > Mounting anchor.

### > Types of locks:



### > Standard colours:

- light grey RAL 7035
- black RAL 9005



# KP Strong Safes grade II-VI, VIII

## KP Strong Safes grade II-VI, VIII

Model	External dimensions [mm]			Internal dimensions [mm]			Weight [kg]	Volume [l]
	height	width	depth	height	width	depth		
KP 45	450	450	455	340	340	320	64	37
KP 67	670	500	495	560	390	360	100	79
KP 100	1000	500	495	890	390	360	130	125
KP 120	1200	500	495	1090	390	360	153	153
KP 150	1500	500	495	1390	390	360	193	195

Product weight is specified for reference only and is subject to change.

### Volume

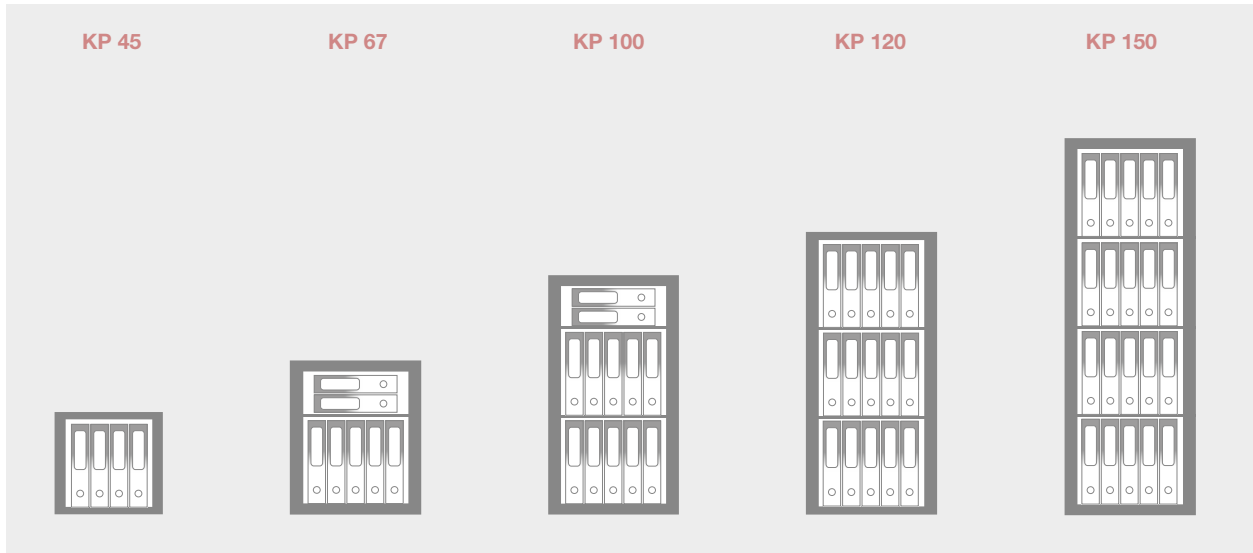

## Technical data of KP Strong Safes grade III

Model	External dimensions [mm]			Internal dimensions [mm]			Weight [kg]	Volume [l]
	height	width	depth	height	width	depth		
KP 67	670	610	615	578	510	459	327	135
KP 100	1000	610	615	908	510	459	515	212
KP 120	1200	610	615	1108	510	459	608	259
KP 150	1500	610	615	1410	510	459	715	330
KP 180	1800	610	615	1710	510	459	850	400

Product weight is specified for reference only and is subject to change.

### Volume

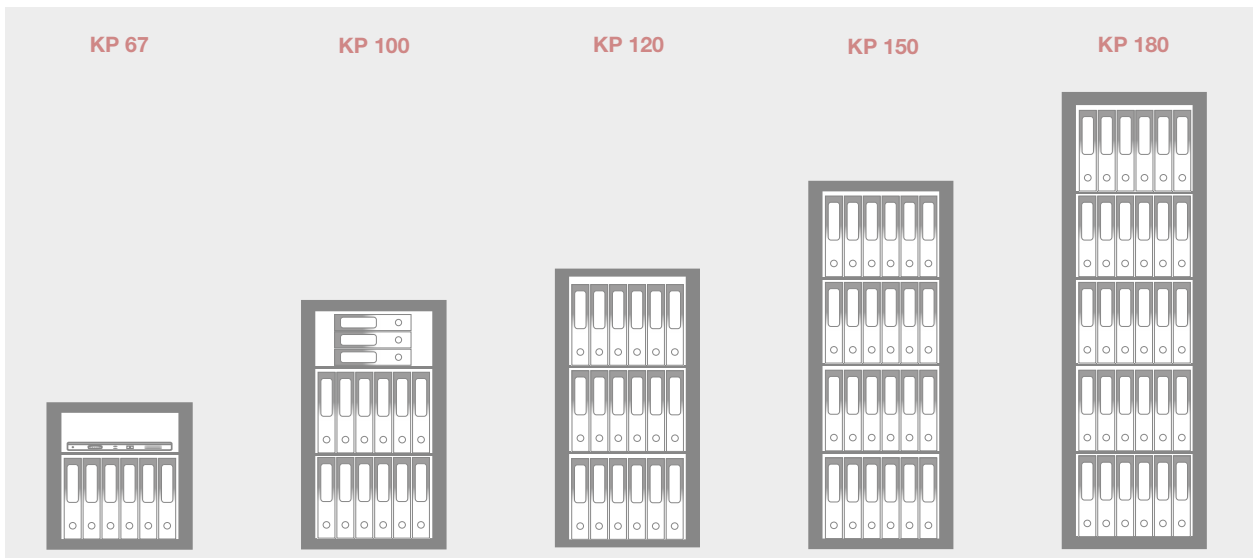

# KP Strong Safes grade II-VI, VIII

## Technical data of KP Strong Safes grade IV-V

Model	External dimensions [mm]			Internal dimensions [mm]			Weight [kg]		Volume [l]
	height	width	depth	height	width	depth	Grade IV	Grade V	
KP 67	670	680	685	508	510	460	517	607	120
KP 100	1000	680	685	838	510	460	765	785	197
KP 120	1200	680	685	1038	510	460	980	910	244
KP 150	1500	680	685	1340	510	460	1093	1010	314

Product weight is specified for reference only and is subject to change.

## Volume

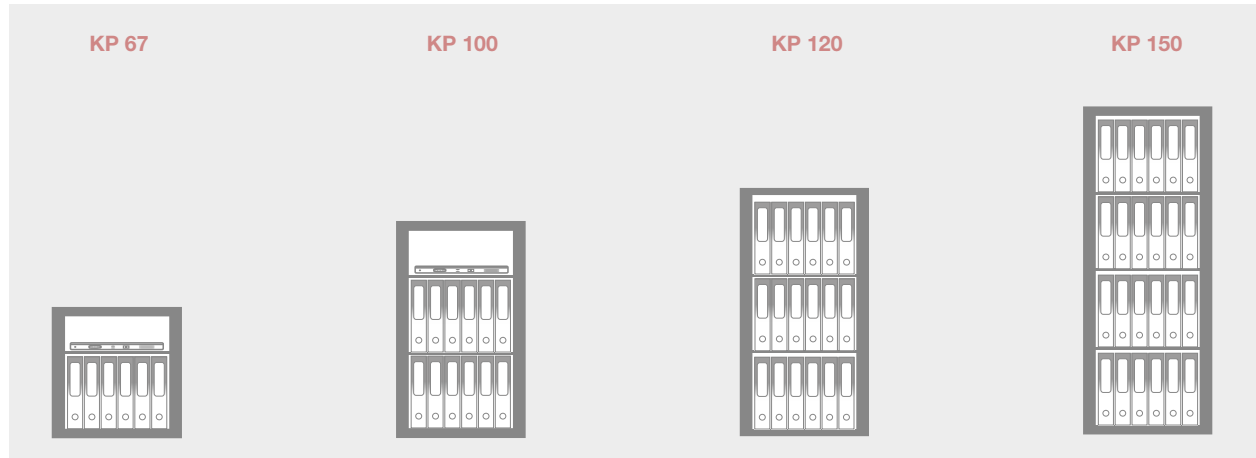

## Technical data of KP Strong Safes grade VI

Model	External dimensions [mm]			Internal dimensions [mm]			Weight [kg]	Volume [l]
	height	width	depth	height	width	depth		
KP 67	670	680	685	508	510	460	660	120
KP 100	1000	680	685	838	510	460	830	197
KP 120	1200	680	685	1038	510	460	975	244
KP 150	1500	680	685	1340	510	460	1185	314
KPP 120	1200	800	775	1038	630	550	1240	360
KPP 150	1500	800	775	1340	630	550	1450	464
KPP 180	1800	800	775	1640	630	550	1625	568

Product weight is specified for reference only and is subject to change.

## Volume

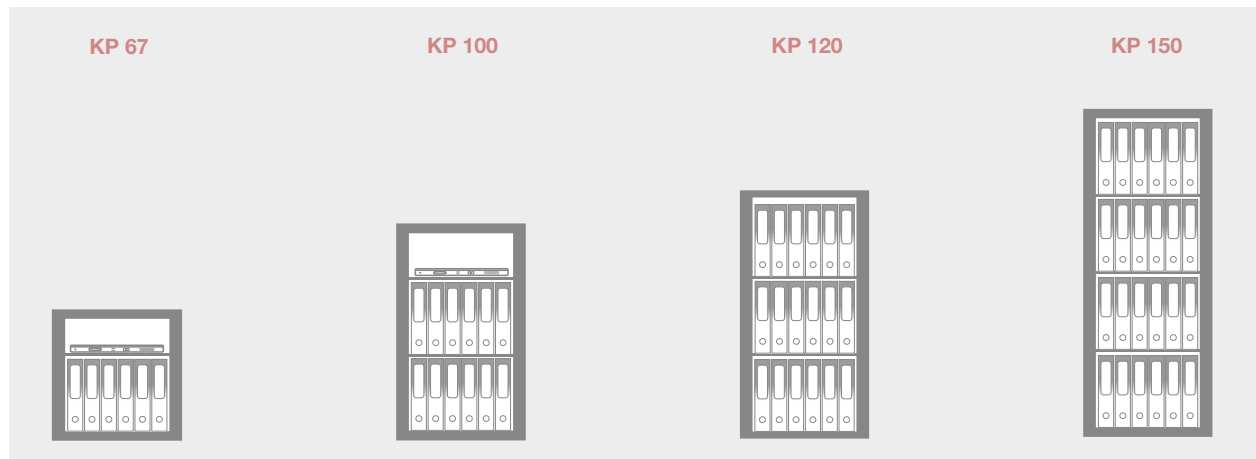

## Volume

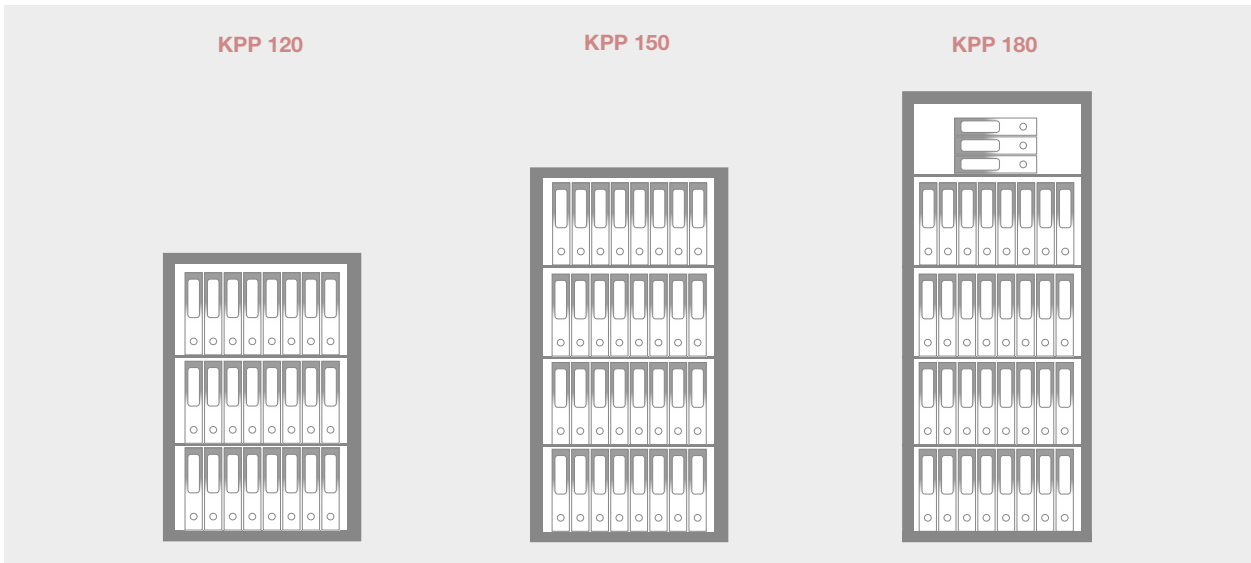

## Technical data of KP Strong Safes grade VIII

Model	External dimensions [mm]			Internal dimensions [mm]			Weight [kg]	Volume [l]
	height	width	depth	height	width	depth		
KP 120	1200	780	765	960	530	460	1420	234
KP 150	1500	780	765	1260	530	460	1700	307
KP 180	1800	780	765	1560	530	460	1950	380

Product weight is specified for reference only and is subject to change.

## Volume

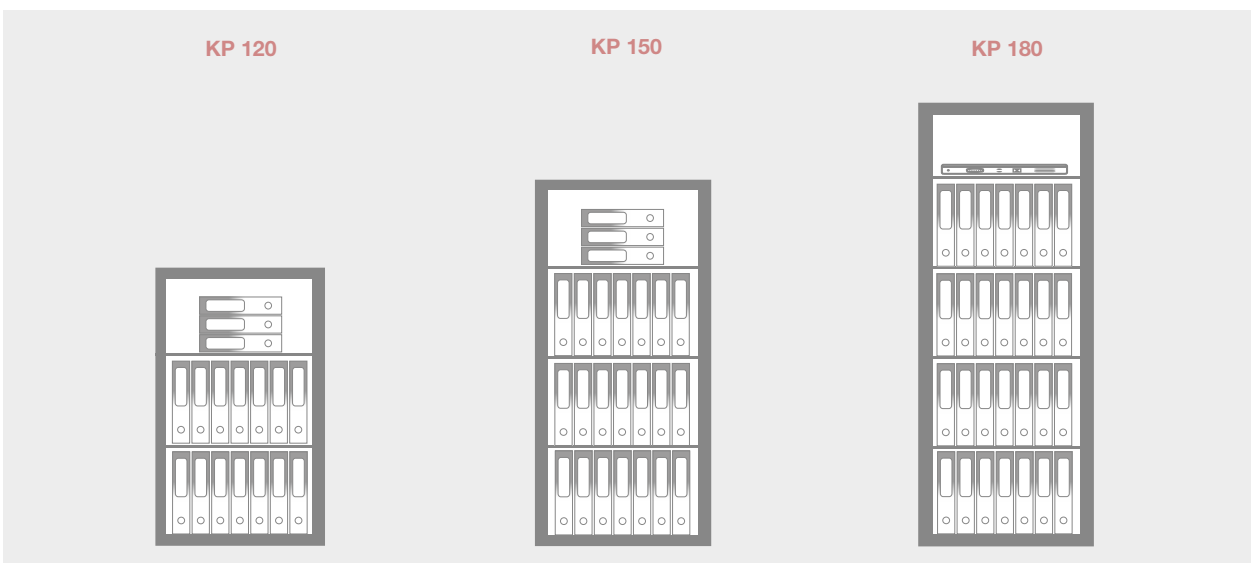

# Light KPL Strong Safes grade III, VI\*



## Certified locks

Independently tested locks of the highest quality: key, combination and electronic.

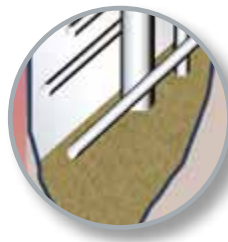

## Reinforced wall structure

Reinforced double-layered wall structure, filled with a special composite.

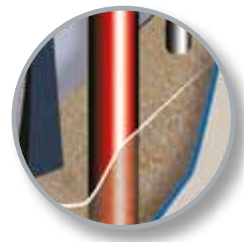

## Anti-burglary reinforcement

Active anti-burglary reinforcement securing against the opening using diamond drill tools.



## Double locks' protection

Double locks' protection composed of covering elements made of high-alloy steel of the highest quality and a mechanism blocking the Strong Safe during attempts of breaking or damaging the lock.



## Complex bolting system

An extensive bolting system equipped with a blockade activated during burglary attempts: depending on the grade, there are four or six horizontal bolts of increased diameter. Reinforced fixed bolt positioned close to hinges ensures door protection against breaking in even after hinges are destroyed.

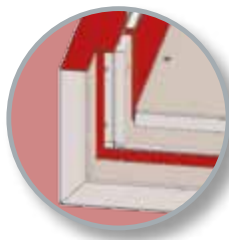

## Fire protection

Light KPL Strong Safes feature a special fire-proof ThermControl® filling. Additional fire insulation is provided by a thermo-active seal, preventing temperature rise inside the Safe.

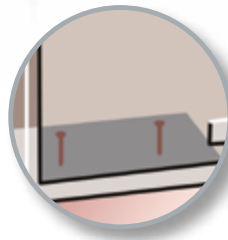

## Floor mounting

Floor mounting option compliant with the guidelines of European Standards.



## Interior equipment options

Optional separately lockable internal boxes, alarm sensors and shelves.



## > Certificates for storing:

- > Valuables in accordance with the PN-EN 1143-1+A1:2009 standard, grade III, VI.

## > Product description:

- > Multi-layered steel structure filled with a special ThermControl® composite with anti-burglary and fire-proofing characteristics.
- > Extra fire insulation provided by a thermo-active seal, preventing temperature rise inside the Strong Safe.
- > Complex bolting system blocking door opening during burglary attempts.
- > Top-quality mechanisms ensuring locks' protection against drilling and breaking in.

## > Equipped with certified locks:

- > B-grade key lock (models in grade III);
- > C-grade key lock and C-grade combination lock (models in grade VI).
- > Optional mounting of any two locks.
- > Mounting holes in the Strong Safe bottom with min. 5 tons resistance against tearing.
- > Laser technology manufacturing provides extraordinary precision of workmanship.
- > Shelf with height adjustment.
- > 24-month warranty.

# Light KPL Strong Safes grade III, VI

# 3 w 1

Burglary protection

Reduced weight

Fire protection

Patent-protected solution

## > Additional equipment

(available depending on the model):

- > Separately lockable internal box (SMART internal box).
- > Additional shelf with height adjustment.
- > Certified locks: key, combination or electronic.
- > Alarm sensors: shock and bolt position sensors.
- > Alarm installation output.
- > Protective sealing.
- > Mounting anchor.

## > Types of locks:



## > Standard colours:

- light grey RAL 7035
- black RAL 9005



## ThermControl®

### How does the unique ThermControl® filling work?

The unique ThermControl® filling, which formula was submitted for patent protection, secures the content of the Strong Safe against fire and against attack using thermal tools.

The innovative ThermControl® formula prevents the material from heating in cases of fire and exposure to high temperatures. The use of the ThermControl® filling guarantees maintaining safe temperature inside the Strong Safe during fire.

Furthermore, the unique characteristics of the ThermControl® filling reduce the weight of Light KPL Strong Safes by more than a half, compared with other products available on the market until now, while ensuring the required level of burglary resistance.

# Light KPL Strong Safes grade III, VI

## Technical data of Light KPL Strong Safes grade III, VI

Model	External dimensions [mm]			Internal dimensions [mm]			Weight [kg]	Volume [l]
	height	width	depth	height	width	depth		
KPL 67	670	616	615	490	450	400	264	88
KPL 100	1000	666	615	820	500	400	338	164
KPL 120	1200	666	615	1020	500	400	410	204
KPL 150	1500	666	615	1320	500	400	481	264
KPL 180	1800	666	615	1620	500	400	561	324
KPPL 120	1200	766	765	1020	600	550	497	337
KPPL 150	1500	766	765	1320	600	550	602	436
KPPL 180	1800	766	765	1620	600	550	698	535
KPPPL 180	1800	1066	765	1620	900	550	860	802

Product weight is specified for reference only and is subject to change.

## Volume



# Light KPL Strong Safes grade III, VI

Technical data of Light KPL Strong Safes grade III, VI

Model	External dimensions [mm]			Internal dimensions [mm]			Weight [kg]	Volume [l]
	height	width	depth	height	width	depth		
KPL 67	670	646	645	460	450	400	390	83
KPL 100	1000	696	645	790	500	400	480	158
KPL 120	1200	696	645	990	500	400	570	198
KPL 150	1500	696	645	1290	500	400	677	258
KPL 180	1800	696	645	1590	500	400	830	318
KPPL 120	1200	796	795	990	600	550	690	327
KPPL 150	1500	796	795	1290	600	550	838	426
KPPL 180	1800	796	795	1590	600	550	973	525
KPPPL 180	1800	1096	795	1590	900	550	1200	787

Product weight is specified for reference only and is subject to change.

## Volume

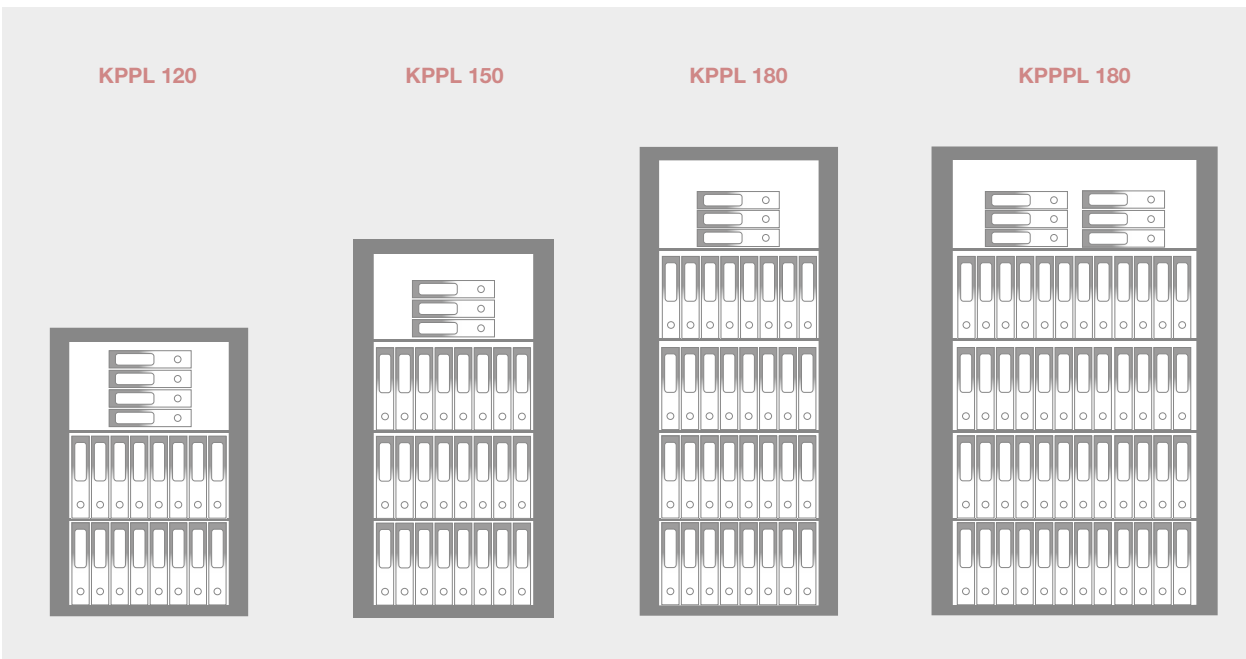
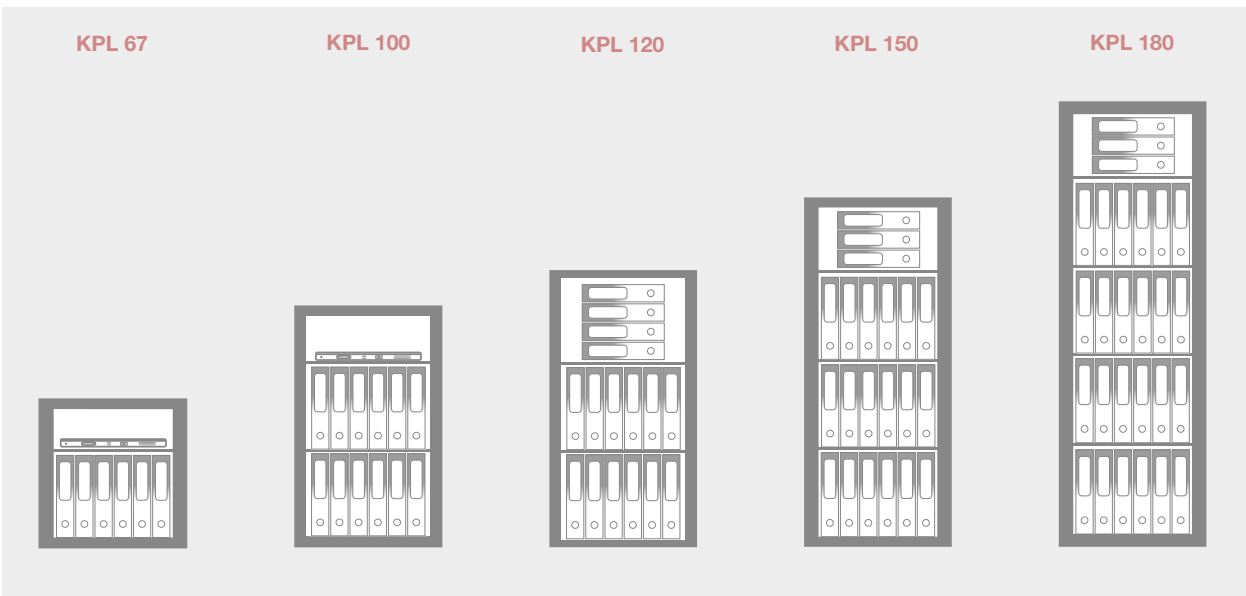



## GERMAN PRECISION

## - POLISH WORKMANSHIP



### > Certificate for storing:

- > Valuables in accordance with the VdS 2344:2012-07, VdS 2450:2011-04 German standard based on EN 1143-1:2005+A1:2009 standard, grade N, I, II.

### > Product description:

- > The KP Strong Safes with VdS certificate are suitable for depositing cash, bills, cheques, stocks, shares, jewelry and other valuables.
- > Highest level of anti-burglary protection thanks to a multi-layered steel structure of the body and door filled with a special composite.

- > Complex bolting system: an anti-burglary blockade activated at the time of a break-in attempt and door protected against pulling out even after hinges are previously cut out.
- > Equipped with certified lock: A- grade key lock.
- > Shelves with height adjustment.
- > Door opening angle of 200 degrees.
- > 24-month warranty.

# KP VdS Strong Safes grade N, I, II

## > Additional equipment:

- > Separately lockable internal box.
- > Additional shelves.
- > Certified locks: key, combination, electronic.
- > Time delay and silent alarm of the lock.
- > Alarm installation output.

## > Types of locks:



## > Standard colours:

- light grey RAL 7035
- black RAL 9005

## Technical data KP VdS Strong Safes grade N

Model	External dimensions [mm]			Internal dimensions [mm]			Weight [kg]	Volume [l]
	height	width	depth	height	width	depth		
KP 5	535	542	530	405	400	315	260	51
KP 6	630	572	570	500	430	355	330	76
KP 8	800	572	570	670	430	355	390	102
KP 9	940	542	530	810	400	315	410	102
KP 11	1170	572	570	1040	430	355	540	158
KP 12	1290	682	640	1160	540	425	710	266
KP 15	1520	682	640	1390	540	425	820	319
KP 16	1660	682	640	1530	540	425	890	351
KP 18	1800	682	640	1670	540	425	950	383

Product weight is specified for reference only and is subject to change.

## Technical data KP VdS Strong Safes grade I

Model	External dimensions [mm]			Internal dimensions [mm]			Weight [kg]	Volume [l]
	height	width	depth	height	width	depth		
KP 5	535	542	530	405	400	315	270	51
KP 6	630	572	570	500	430	355	340	76
KP 8	800	572	570	670	430	355	400	102
KP 9	940	542	530	810	400	315	420	102
KP 11	1170	572	570	1040	430	355	550	158
KP 12	1290	682	640	1160	540	425	720	266
KP 15	1520	682	640	1390	540	425	830	319
KP 16	1660	682	640	1530	540	425	900	351
KP 18	1800	682	640	1670	540	425	960	383

Product weight is specified for reference only and is subject to change.

## Technical data KP VdS Strong Safes grade II

Model	External dimensions [mm]			Internal dimensions [mm]			Weight [kg]	Volume [l]
	height	width	depth	height	width	depth		
KP 5	535	542	530	405	400	315	330	330
KP 6	630	572	570	500	430	355	395	395
KP 8	800	572	570	670	430	355	460	460
KP 9	940	542	530	810	400	315	500	500
KP 11	1170	572	570	1040	430	355	675	675
KP 12	1290	682	640	1160	540	425	850	850
KP 15	1520	682	640	1390	540	425	940	940
KP 16	1660	682	640	1530	540	425	970	970
KP 18	1800	682	640	1670	540	425	1090	1090

Product weight is specified for reference only and is subject to change.



The company KONSMETAL possesses the NATO Commercial and Government Entity Code, constituting a distinguishing mark in the NATO codification System.

# Cabinets

## Security Cabinets for Documents grade A, B, C



### > Certificates for storing:

- > Confidential documents grade A, secret documents grade B, top secret documents grade C in accordance with KT/101/IMP:2008(6), meeting the requirements of Instruction No 57 and 58 of the Ministry of National Defense of December 2011.
- > Compliant with the requirements of the Regulation of the Council of Ministers of 01.06.2010 on the organization and functioning of secret offices.
- > Classified documents TYPE 1,2,3 in accordance with the Regulation of the Council of Ministers of 29.05.2012 on the physical security measures used to protect classified information.

### > Product description:

- > Cabinet body and doors made of burglar-resistant steel plates.
- > Cabinets are equipped with the following locks (depending on the selected model):
  - > A-grade - a certified A-grade key lock;
  - > B-grade - two certified locks: B-grade key lock and B-grade combination lock;
  - > C-grade - two certified locks: B-grade key lock and B-grade combination lock.

- > The B-grade combination lock in a B-grade cabinet is protected against destruction, including drilling.
- > The B-grade combination lock in a C-grade cabinet is protected against destruction, including drilling and radiological attack.
- > Cabinet doors are locked on three sides with a powerful boltwork mechanism.
- > Shelves with height adjustment.
- > Door opening angle:
  - > In A-grade products - 120°;
  - > In B- and C-grade products - 90° (single-door cabinets) or 180° (double-door cabinets).
- > 24-month warranty.

### > Additional equipment

(available depending on the model):

- > Separately lockable internal box.
- > Additional shelf with height adjustment.
- > Certified locks: key, combination or electronic.
- > Protective sealing.
- > Two mounting holes in the cabinet's bottom.
- > Two mounting anchors.

# Security Cabinets for Documents grade A, B, C

## Technical data of Security Cabinets for Documents grade A

Model	External dimensions [mm]			Internal dimensions [mm]			Weight [kg]	Volume [l]
	height	width	depth	height	width	depth		
MS1M/A 150	1500	700	400	1425	685	340	54	332
MS1M/A 190	1900	700	400	1825	685	340	63	425
MS2M/A 190	1900	1000	400	1825	985	340	78	611

Product weight is specified for reference only and is subject to change.

## Technical data of Security Cabinets for Documents grade B

Model	External dimensions [mm]			Internal dimensions [mm]			Weight [kg]	Volume [l]
	height	width	depth	height	width	depth		
SD1/B 150S	1500	600	440	1490	580	360	106	311
SD1/B 185S	1850	600	440	1840	580	360	127	384
SD2/B 185D	1850	1000	440	1840	980	360	195	649

Product weight is specified for reference only and is subject to change.

## Technical data of Security Cabinets for Documents grade C

Model	External dimensions [mm]			Internal dimensions [mm]			Weight [kg]	Volume [l]
	height	width	depth	height	width	depth		
SD1/C 150S	1500	600	440	1397	500	318	139	222
SD1/C 185S	1850	600	440	1747	500	318	172	278
SD2/C 185D	1850	1000	440	1747	900	318	275	500

Product weight is specified for reference only and is subject to change.

### > Types of locks:



### > Standard colours:

■ light grey RAL 7035



## SD Security Cabinets for Documents grade S1, S2, 0



### > Certificates for storing:

- > Classified documents grade S1 and classified documents grade S2 in accordance with the EN 14450:2006 standard.
- > Classified documents grade 0 in accordance with the EN 1143-1+A1:2009 standard.
- > Confidential documents TYPE 2,3,4 in accordance with the requirements of the Regulation of the Council of Ministers of 29.05.2012 on the physical security measures used to protect classified information.
- > Firearms and ammunition in accordance with the requirements of KT/101/IMP/2008.

### > Product description:

- > S1 grade is suitable for the storage of documents classified as 'secret'.
- > S2 and 0 grades are suitable for the storage of documents classified as 'top secret'.
- > Available in a single-door (SD1) and double-door (SD2) version.
- > Multi-layered steel structure.
- > Cabinet body and doors made of burglar-resistant steel plates.
- > Complex bolting system.
- > Suitable for computer hardware storage.

# SD Security Cabinets for Documents grade S1, S2, 0

- > Cabinets are equipped with the following locks (depending on the selected model):
  - > S1-grade – a certified A-grade key lock;
  - > S2-grade – a certified B-grade combination lock;
  - > 0-grade – two certified B-grade combination locks.
- > Two mounting holes in the cabinet's bottom.
- > 24-month warranty.

## > Additional equipment:

- > Separately lockable internal box.
- > Certified locks: key, combination or electronic.
- > Additional shelf with height adjustment.
- > Protective sealing.
- > Two mounting anchors.

## > Types of locks:



## > Standard colours:

- light grey RAL 7035

### Technical data of SD Security Cabinets for Documents grade S1 (TYPE 2)

Model	External dimensions [mm]			Internal dimensions [mm]			Weight [kg]	Volume [l]
	height	width	depth	height	width	depth		
SD1/S1 150S	1500	600	440	1490	580	360	106	311
SD1/S1 185S	1850	600	440	1840	580	360	127	384
SD2/S1 185D	1850	1000	440	1840	980	360	195	649

Product weight is specified for reference only and is subject to change.

### Technical data of SD Security Cabinets for Documents grade S2 (TYPE 3)

Model	External dimensions [mm]			Internal dimensions [mm]			Weight [kg]	Volume [l]
	height	width	depth	height	width	depth		
SD1/S2 150S	1500	600	440	1397	500	318	139	222
SD1/S2 185S	1850	600	440	1747	500	318	172	278
SD2/S2 185D	1850	1000	440	1747	900	318	275	500

Product weight is specified for reference only and is subject to change.

### Technical data of SD Security Cabinets for Documents grade O (TYPE 4)

Model	External dimensions [mm]			Internal dimensions [mm]			Weight [kg]	Volume [l]
	height	width	depth	height	width	depth		
SD1/O 150S	1500	600	440	1397	500	318	232	222
SD1/O 185S	1850	600	440	1747	500	318	293	293
SD2/O 185D	1850	1000	440	1747	900	318	457	526

Product weight is specified for reference only and is subject to change.

# Security Cabinets for Documents grade A



## > Certificates for storing:

- > Confidential documents grade A in accordance with KT/101/IMP:2008(6), compliant with the requirements of Instruction No 57 and 58 of the Ministry of National Defense of December 2011.

## > Product description:

- > Comfortable and safe storage of documents classified as 'confidential'.
- > Suitable for computer hardware storage.
- > Reinforced body and doors made of steel with high resistance to attack.
- > Complex bolting system.
- > Elegant design matches any interior.
- > Comfortable in operation with an ergonomic door handle.
- > Equipped with a certified A-grade key lock.
- > Standard equipment includes four shelves with height adjustment.
- > Door opening angle of 180 degrees.
- > 24-month warranty.

## > Additional equipment:

- > Separately lockable internal box.
- > Additional shelf with height adjustment.

- > Locks: key, combination or electronic.
- > Protective sealing.
- > Two mounting holes.
- > Mounting anchors.

## > Types of locks:



## > Standard colours:

- light grey RAL 7035

## Technical data of Security Cabinets for Documents grade A

Model	External dimensions [mm]			Internal dimensions [mm]			Weight [kg]	Volume [l]
	height	width	depth	height	width	depth		
MS2/A-4/2	1900	1000	400	1780	990	350	92	616

Product weight is specified for reference only and is subject to change.





› **Product description:**

- › Cabinet body and doors made of burglar-resistant steel plates.
- › Equipped with EuroLocks type lock with a handle.
- › Three way blocking door structure.
- › Shelves with height adjustment.
- › Interior hinges.
- › Door opening angle: 120°.
- › 24-month warranty.

› **Additional equipment:**

- › Single-door or double-door height extension.
- › Separately lockable internal box.
- › Additional shelf with height adjustment.

› **Types of locks:**



› **Standard colours:**

- light grey RAL 7035

**Technical data of Office Cabinets**

Model	External dimensions [mm]			Internal dimensions [mm]			Weight [kg]	Volume [l]
	height	width	depth	height	width	depth		
MS2 D199	1990	1200	400	1915	1185	362	82	821
MS2 199	1990	1000	400	1915	985	362	72	683
MS2 M199	1990	800	400	1915	785	362	62	544
Height extension unit MS2D	470	1200	400	395	1195	362	23	171
Height extension unit MS2	470	1000	400	395	995	362	20	142
Height extension unit MS2M	470	800	400	395	795	362	17	114

Product weight is specified for reference only and is subject to change.



# Deposit Drop Safes

## SECURE CASH DEPOSITING AT A REASONABLE PRICE



### > Certificates for storing:

- > Valuables in accordance with KT/101/4/IMP:2008, based on the PN-EN 14450 standard, grade S1.

### > Product description:

- > Modern Drop Safes for retail facilities and office use.
- > Suitable for depositing cash, stocks, shares and documents by deposit drop slot or deposit drop drawer.
- > Optional laptop storage.
- > Heavy-duty steel body with high resistance to attack.
- > Reinforced door panel including an additional cover of the bolt mechanism and lock.
- > Drop slots secured with an A-grade certified lock.
- > Drop slot can be mounted on the side or back of the Safe. Deposit drop drawer is mounted on the front of the Safe.
- > Models with electronic locks are equipped with a complex system of bolts (vertical bolts) and a handle.
- > 24-month warranty.

### > Additional equipment

(available depending on the model):

- > Additional shelves.
- > Handgun holders.
- > Certified locks: key, combination, electronic.

### > Types of locks:



### > Standard colours:

- light grey RAL 7035
- black RAL 9005

# Koliber Deposit Drop Safes grade S1

## Technical data of Koliber Safes with deposit drop slot grade S1

Model	Dimensions			Weight [kg]	Shelves [pcs]
	height	width	depth		
Koliber W 45-Laptop15"	450	400	370	42	1
Koliber W 62-Laptop15"	620	400	370	52	1
Koliber W 45-Laptop17"	450	490	370	46	1
Koliber W 62-Laptop17"	620	490	370	56	1

Product weight is specified for reference only and is subject to change.

## Technical data of Koliber Safes with deposit drop drawer grade S1

Model	Dimensions			Weight [kg]	Shelves [pcs]
	height	width	depth		
Koliber+WSX 62-Laptop 15"	620	400	370	55	1
Koliber+WSX 62-Laptop 17"	620	490	370	59	1

Product weight is specified for reference only and is subject to change.

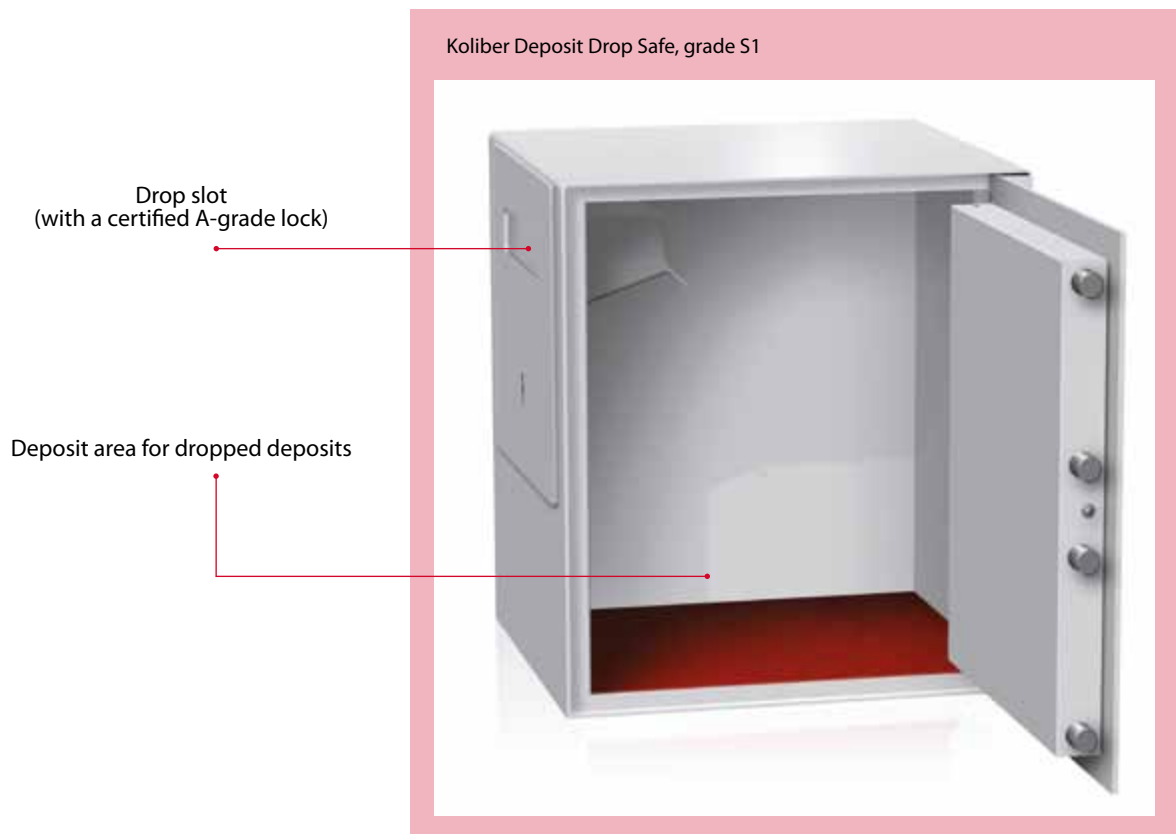

### Maximum dimensions of the deposited package:

Deposit - type	Maximum dimensions of the dropped package [mm]		
	height	width	depth
Drop slot	38	170	-
Drop drawer	25	174	105

# FUNCTIONAL SAFE

## WITH QUICK

## CASH DEPOSITING



### > Certificates for storing:

- > ML with a deposit drop drawer (ML+WSX): valuables in accordance with KT/101/4/IMP: 2008, compliant with PN-EN 14450, grade S1.
- > ML with a drop slot (MLW): valuables in accordance with KT/101/4/IMP:2008, compliant with PN-EN 14450, grade S1.

### > Product description:

- > Quick and easy way to deposit cash, stocks, shares and documents, using a deposit drop slot or a deposit drop drawer.
- > Both the slot and the drawer are closed with a cover secured with a certified A-grade lock, which prevents fishing (unauthorized removal) of dropped packages. Additional, effective anti-fishing protection is provided by a special comb.
- > The wide range of sizes allows selecting the right product for individual purposes.
- > High-quality steel body with high attack resistance.

- > Improved protection of bolt system.
- > 24-month warranty.

### > Additional equipment

(available depending on the model):

- > Separately lockable internal box.
- > Additional shelf.
- > Alarm installation output.
- > Handgun holders.
- > Certified locks: key, electronic.
- > Protective sealing.
- > Mounting anchors.

### > Types of locks:



### > Standard colours:

- light grey RAL 7035
- black RAL 9005

# ML Deposit Drop Safes grade S1

Technical data of ML Safes with deposit drop slot grade S1



Model	Dimensions [mm]			Weight [kg]	Shelves [pcs]
	height	width	depth		
MLW 45	450	400	440	49	1
MLW 67	670	400	440	60	1
MLW 85	850	490	440	80	2
MLW 100	1000	490	440	90	2

Product weight is specified for reference only and is subject to change.

Technical data of of ML Safes with deposit drop drawer grade S1



Model	Dimensions [mm]			Weight [kg]	Shelves [pcs]
	height	width	depth		
ML+WSX 45	450	400	440	51	1
ML+WSX 67	670	400	440	65	1
ML+WSX 85	850	490	440	83	2
ML+WSX 100	1000	490	440	93	2

Product weight is specified for reference only and is subject to change.

Drop slot  
(with certified A-grade lock)

Deposit area  
for dropped deposits



Maximum dimensions of the deposited package:

Deposit - type	Maximum dimensions of the dropped package [mm]		
	height	width	depth
Drop slot	38	170	-
Drop drawer	25	174	105

# EXCEPTIONALLY STRONG DEPOSIT DROP SAFE



> **Certificates for storing:**

- > Valuables in accordance with the PN-EN 14450:2006 standard, grade S2.
- > Classified documents TYPE 3 in accordance with the Regulation of the Council of Ministers of 29 May 2012 on the physical security measures used to protect classified information.
- > Firearms and ammunition:
  - > in accordance with the requirements of KT/101/IMP/2008;
  - > compliant with the requirements of the Regulation of the Minister of Internal Affairs and Administration of 03.04.2000 on the storage, carrying and keeping records of weapons and ammunition.

> **Product description:**

- > Used mainly in offices and retail facilities.
- > Convenient and safe way to deposit cash, stocks, shares and documents, etc.
- > Special safe filling significantly improves protection of deposited objects.
- > Complex bolt system blocks the door at a burglary attempt.

- > Reinforced door design.
- > A unique Anti-burglary Self Locking System significantly increases the Safe's resistance to attack by hammer or crowbar.
- > Drop mechanisms protected against fishing (unauthorized removal) of deposited valuables.
- > Drop slots and drop drawers secured with a certified A-grade lock.
- > 24-month warranty.

> **Additional equipment**

(available depending on the model):

- > Separately lockable internal box.
- > Additional shelf with height adjustment.
- > Alarm installation output.
- > Time delay and silent alarm of the lock.
- > Handgun holders.
- > Certified locks: key, combination, electronic.
- > Protective sealing.
- > Mounting anchors.

> **Types of locks:**



> **Standard colours:**

- light grey RAL 7035
- black RAL 9005

# ML STRONG Deposit Drop Safes grade S2

Technical data of ML STRONG Safes with deposit drop slot grade S2 

Model	Dimensions [mm]			Weight [kg]	Shelves [pcs]
	height	width	depth		
MLW STRONG 45	450	400	440	63	1
MLW STRONG 67	670	400	440	80	1
MLW STRONG 85	850	490	440	103	2
MLW STRONG 100	1000	490	440	117	2

Product weight is specified for reference only and is subject to change.

Technical data of ML STRONG Safes with deposit drop drawer grade S2 

Model	Dimensions [mm]			Weight [kg]	Shelves [pcs]
	height	width	depth		
ML STRONG+WSX 45	450	400	440	66	1
ML STRONG+WSX 67	670	400	440	83	1
ML STRONG+WSX 85	850	490	440	106	2
ML STRONG+WSX 100	1000	490	440	120	2

Product weight is specified for reference only and is subject to change.



Maximum dimensions of the deposited package:

Deposit - type	Maximum dimensions of the dropped package [mm]		
	height	width	depth
Drop slot (side, back)	38	170	-
Drop slot (top)	18	98	-
Drop drawer	25	174	105



## SAFE AND QUICK CASH DEPOSITING

### > Certificates for storing:

- > Valuables in accordance with the PN-EN 1143-2:2004 standard, grade II.

### > Product description:

- > Designed for depositing cash, stocks, shares and documents with no need to open the device when dropping packages into the Safe.
- > A perfect solution for secure cash handling in shops, offices and other places where money is deposited and handled, e.g. stores, gas stations, jewelry shops and restaurants.
- > Effective protection against robbery or burglary for cash overflow at cash desks or teller stations.
- > Deposited assets can only be accessed by authorized people.
- > Drum allows easy and convenient depositing and ensure protection against fishing.
- > Optional installation of any two locks.
- > Equipped with shelves with height adjustment (depending on the model).
- > Construction based on the SG Safe.
- > 24-month warranty.

### > Additional equipment

(available depending on the model):

- > Separately lockable internal box.
- > Drum blockade.
- > Additional shelf with height adjustment.
- > Certified locks: key, combination, electronic.
- > Alarm sensors: shock and bolt position sensors.
- > Time delay and silent alarm of the lock.
- > Alarm installation output.
- > Mounting anchors.



### > Types of locks:



### > Standard colours:

- light grey RAL 9002
- light grey RAL 7035
- black RAL 9005

### Technical data of SG Safes with a Deposit Drum grade II



Model	External dimensions [mm]			Internal dimensions [mm]			Weight [kg]	Volume [l]
	height	width	depth	height	width	depth		
SG 48+WBX3	700	480	480	255	360	300	152	28
SG 70+WBX3	920	480	480	387	360	300	159	42
SG 100+WBX3	1220	510	480	687	390	300	210	80
SG 120+WBX3	1420	510	480	887	390	300	245	104

Product weight is specified for reference only and is subject to change.

Deposit type	Maximum dimensions of the dropped package [mm]			Grade
	height	width	depth	
Drop slot WBX3	55	225	140	II

## DEPOSITING CASH

## IN KP STRONG SAFES

### > Certificates for storing:

- > Valuables in accordance with the PN-EN 1143-2:2004 standard, grade II.

### > Product description:

- > Designed for depositing cash, stocks, shares and documents without the need of opening the Safe.
- > Provides a perfect solution for secure cash management in retail outlets, offices and all areas where a money lodgement system is required.
- > More robust construction based on KP Strong Safe.
- > Deposit drum for easy insertion of deposits without safe unlocking, equipped with an anti-fishing protection.
- > Extensive bolt system: horizontal bolts and a fixed bolt.
- > Access to deposits only by authorized personnel.
- > Overnight cover of valuables and cash are allowed.
- > Equipped with shelves with height adjustment (depending on the model).
- > 24-month warranty.

### > Additional equipment

(available depending on the model):

- > Separately lockable internal box (SMART internal box).
- > Additional shelf with height adjustment.
- > Certified locks: key, combination, electronic.
- > Optional mounting of two locks.
- > Alarm sensors: shock and bolt position sensors.
- > Alarm installation output.
- > Time delay and silent alarm of the lock.
- > Protective sealing.
- > Two mounting anchors.



### > Types of locks:



### > Standard colours:

- light grey RAL 7035
- black RAL 9005

Technical data of KP Strong Safes with Deposit Drum grade II



Model	External dimensions [mm]			Internal dimensions [mm]			Weight [kg]	Volume [l]
	height	width	depth	height*	width	depth		
KP 100+WBX3	1000	580	570	460	420	330	190	64
KP 120+WBX3	1200	580	570	660	420	330	204	91
KP 150+WBX3	1500	580	570	960	420	330	247	133

Product weight is specified for reference only and is subject to change.

Maximum dimensions of the deposited package:

Model	dimensions of the deposited package [mm]			Grade
	height	width	depth	
Drop slot WBX3	55	225	140	II

\* Usable deposit height.

# SW Deposit Drop Slot Cassettes



## > Product description:

- > Convenient and quick depositing of cash, accounting receipts and checks during business hours.
- > Mountable on or under a desktop.
- > Single-layered cassette body structure, 3 mm thick.
- > Drop slot protected against fishing (deposit removal).
- > Removable canvas bag for 300-400 banknotes.
- > Equipped with a key or electronic lock.
- > Optional time delay in electronic lock.
- > An additional canvas bag can be ordered.
- > 24-month warranty.

## > Types of locks:



## > Standard colours:

- light grey RAL 9002
- light grey RAL 7035
- black RAL 9005

## Technical data of SW Deposit Drop Slot Cassettes

Model	Dimensions [mm]			Dimensions of drop slot [mm]	Weight [kg]	Volume [l]
	height	width	depth			
SW – EM*	300	120	250	10 x 108	8	3
SW – K**	300	120	250	10 x 108	8	3
SW – Eurolock***	300	120	250	10 x 108	8	3

Product weight is specified for reference only and is subject to change.

- \* Electronic lock.
- \*\* Key lock.
- \*\*\* Eurolock lock.



# Products for cashiers





## > Certificates for storing:

- > Valuables in accordance with the PN-EN 1143-1:2012 standard, grade I.
- > Firearms and ammunition:
  - > in accordance with the requirements of KT/101/IMP/2008;
  - > compliant with the requirements of the Regulation of the Minister of Internal Affairs and Administration of 03.04.2000 on the storage, carrying and keeping records of weapons and ammunition.

## > Product description:

- > Teller Safes are used in cash desks and other places where cash handling and cash depositing takes place. They secure cash operated by cashiers at cash desks.
- > They are equipped with a deposit drop slot drawer which allows to move cash overflow into the deposit area. The drawer is used for storing cash float only to perform current transactions.
- > The drawer and the main door to the deposit area are locked independently.
- > Double-layered structure of the safe body and multi-layered door structure.

- > Optional electronic lock with time delay opening function protects the cashier and deposited valuables.
- > Advanced bolt system.
- > The deposit area of the Safe (main compartment) is equipped with one fixed shelf.
- > The product is suitable for floor mounting.
- > 24-month warranty.

## > Additional equipment

(available depending on the model):

- > Cash cassette.
- > Certified locks: key, combination or electronic.
- > Alarm installation output.
- > Protective sealing.
- > Two mounting anchors.

## > Types of locks:



## > Standard colours:

- light grey RAL 7035
- black RAL 9005

# LS+ Teller Safes grade I

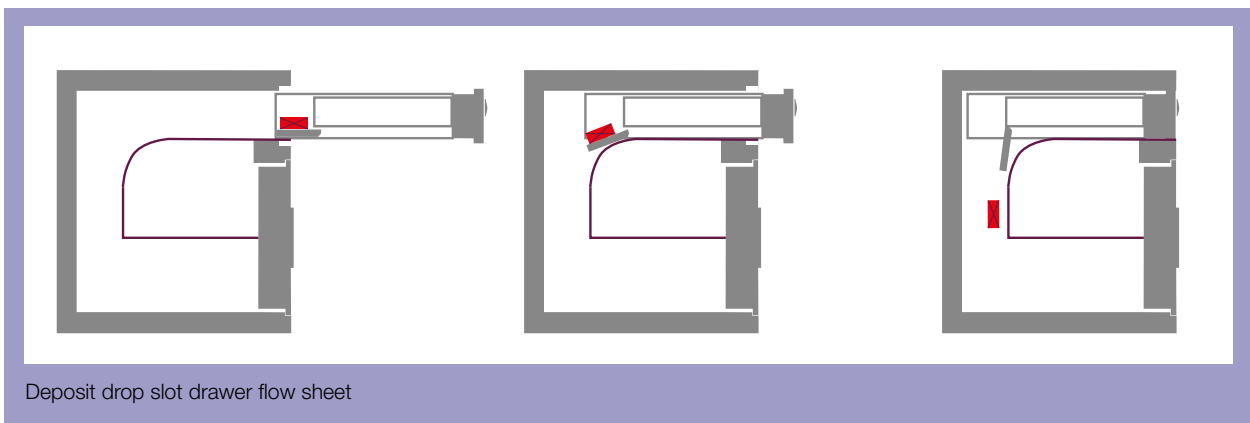
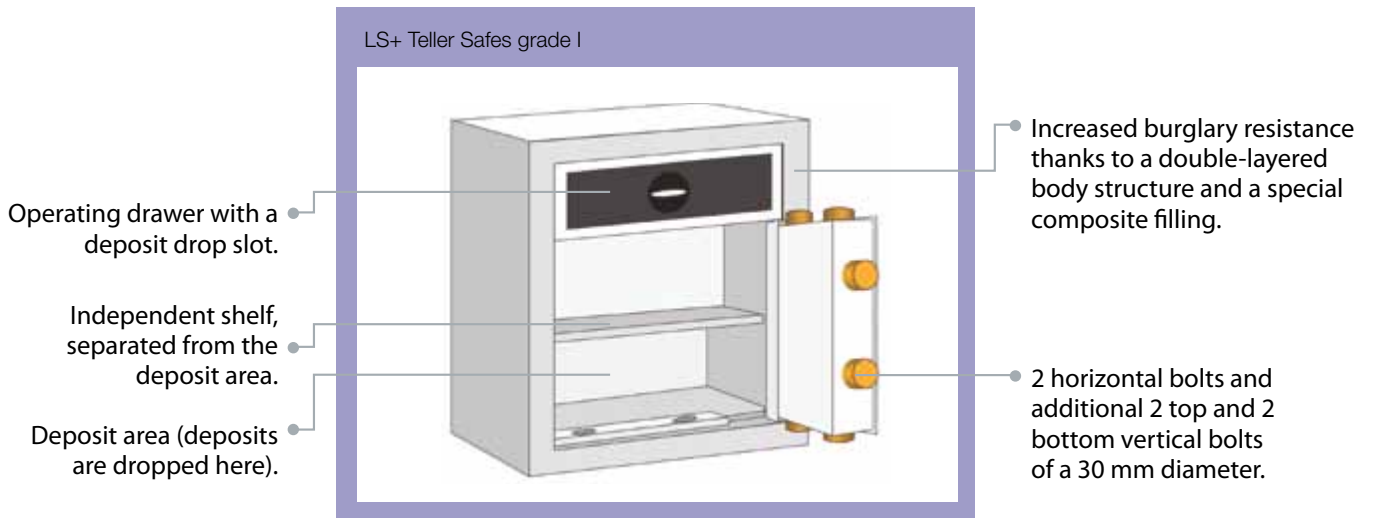

## Technical data of LS+ Teller Safes grade I

Model	Dimensions [mm]			Drawer dimensions [mm]			Weight [kg]	Volume [l]
	height	width	depth	height	width	depth		
LS 67+	670	490	440	90	330	195	115	47,8

Product weight is specified for reference only and is subject to change.

INNOVATIVE

NEXT GENERATION

ANTI- BURGLARY DEVICE



> Certificates for storing:

- > Valuables in accordance with the PN-EN 14450:2006 standard, grade S2.
- > Valuables in accordance with the PN-EN 1143-1:2012 standard, grade I.

> Product description:

- > Anti-robbery device for safe storage of money valuables.
- > Designed for floor mounting under the cashier's desk.
- > Electronically controlled drawer access; option of setting a delayed opening function for each drawer (up to 99 minutes).
- > All drawers are secured against removing their contents through any other drawer.
- > Possible English menu.
- > Individual options possible to configure by users.
- > User authorization with a code.

- > Automatic cashiers' blockade system. When the Safe is operated by one cashier, the other authorized users have no access to the device.

- > Electronic night blockade.
- > Time-blockade system of the Multi-safe.
- > Blocking with a mechanical A-grade certified key lock, compliant with EN 1300.
- > Remote Multi-safe management using a computer network.
- > Can be operated by the cashier using a computer application.
- > Time delay and silent alarm of the lock.
- > Event audit with a capacity of 20 thousand logs.
- > Partial drawers closure signaling system.
- > Alarm installation output.
- > Suitable for floor mounting.
- > 24-month warranty.

# Electronic Multi-safes XS grade S2, I

## > Additional equipment:

- > Emergency opening system with time delay.
- > Optional printer connection for print-outs of the event log.
- > Ethernet port and serial port.
- > Cash cassette with a lid and lock, with note and coin compartments.
- > Operation and deposit cassette.
- > Closed deposit drop cassette.
- > Replacing a mechanical lock (which blocks all drawers) with an electronic lock.
- > Seismic sensor.
- > Optional backup power supply.
- > Optional individual configuration.
- > Two mounting anchors.



## > Innovative solutions:

- > **Energy efficient** – Very low energy consumption (approx. 1.5 W) is characteristic for Multi-safes.
- > **Unique emergency battery power supply system** – The minimum guaranteed battery working time is 8 hours. In case of longer power failures, batteries can be changed to ensure continuous operation.
- > **Low maintenance costs** – The unique device structure requires no periodical inspections or maintenance.

- > **Reliability of mechanisms** – The tests conducted proved that the reliability of mechanisms exceeds the warranty period significantly: results in more than 400 thousand cycles and resistance to negative temperatures.
- > **Intuitive operation** – user friendly menu based on mobile phones solutions.
- > **Unique drawer blocking system** – based on heavy-duty bolts.

Technical data of Electronic Multi-safe XS grade S2, I

Model	Dimensions [mm]			Weight [kg]		Drawer volume [l]
	height	width	depth	Grade S2	Grade I	
3-drawer Multi-safe	633	500	475	130	130	49
Drawer type	Dimensions [mm]			Drawer equipment – available as an option		
	height	width	depth			
Operating	100	390	340	Case for coins and bills		
Deposit	100	390	340	-		
Insert	200	390	290	Drop slot + case for coins and bills		

Model	Dimensions [mm]			Weight [kg]		Drawer volume [l]
	height	width	depth	Grade S2	Grade I	
4-drawer Multi-safe	633	500	475	130	130	45
Drawer type	Dimensions [mm]			Drawer equipment – available as an option		
	height	width	depth			
Operating	85	390	340	Case for coins and bills		
Deposit	85	390	340	-		
Deposit	85	390	340	-		
Insert	110	390	290	Drop slot + case for coins and bills		

Product weight is specified for reference only and is subject to change.



# Electronic Multi-safes XS grade S2, I



Upper drawer designed for coins and banknotes storage.



Simple, fully intuitive handling.



Bottom drawer designed as a secured deposit drop slot, equipped with a portable cash cassette.



Emergency power supply.



Clear display. Excellent visibility, even in bright outside light.



User friendly interface.

## Transfer Safes grade II, V



Laser  
technology

### > Certificates for storing:

- > Valuables in accordance with the PN-EN 1143-2:2004 standard, grade II, V.

### > Product description:

- > Designed for two-way handling of deposits without direct contact between the person making the deposit and the recipient. Electronic blockade prevents simultaneous door opening on both sides.
- > Door position on opposite sides facilitates a convenient and fast transfer (e.g. within a bank) and receipt (from the outside) of deposits without the need of entering and leaving the building.
- > Multi-layered steel safe structure.
- > Manufactured using laser technology.

- > Access control based on remote management of the device locks.
- > Complex bolt system.
- > Sensors system to monitor bolt and door position, as well as the electronic lock status.
- > Warning-alarm system emitting sound and light signals or signals to the exterior monitoring system (option):
  - > Lock or door opening signal;
  - > Open door signal;
  - > Bolt position control system emitting signals of a burglary attempt.
- > Equipped with certified locks.
- > Suitable for floor mounting.
- > Equipment customization options adapted to the Client's needs.
- > Emergency power supply.
- > 24-month warranty.

### > Additional equipment:

- > Alarm sensors: shock, bolt and door position sensors.
- > Alarm installation output.
- > Sensor monitoring the presence of the deposit in the Transfer Safe.
- > Mounting anchors.

### > Types of locks:



### > Standard colours:

- light grey RAL 7035
- black RAL 9005



## Technical data of Transfer Safes grade II

Model	Dimensions [mm]			Weight [kg]
	height	width	depth	
KPP 120/120-K/II	1200	800	1100	420
KPP 120/120-K/II/W	1200	800	1100	400
K-SII/1 KPII	800	420	850	175
K-SII/1 KPII/W	800	420	850	175
K-SII/2 KPII	800	670	850	249
K-SII/2 KPII/W	800	670	850	249

Product weight is specified for reference only and is subject to change.

## Technical data of Transfer Safes grade V

Model	Dimensions [mm]			Weight [kg]
	height	width	depth	
KPP 120/120-SK/V	1200	800	1100	1370
KPP 120/120-SK/V/W	1200	800	1100	1350

Product weight is specified for reference only and is subject to change.



# Deposit Strong Safes

# Electronic Deposit Strong Safes grade II-VI

## > Certificates for storing:

- > Valuables in accordance with the PN-EN 1143-2:2004 standard, grade II-VI.

## > Product description:

- > Electronic Deposit Strong Safe for round-the-clock self-depositing of valuables without the cashier's participation.
- > Device available in three versions:
  - > Stand-alone Deposit Strong Safe;
  - > Built in wall-mounted Deposit Strong Safe with the input unit door and receiving unit door on the same side;
  - > Built in wall-mounted Deposit Strong Safe with a drop chute and the input unit door on the opposite side to receiving unit door.
- > The Deposit Strong Safe comprises a drop compartment and the deposit compartment.
- > The drop compartment has a drum opened with a lever, an electronic unit with an illuminated display and keyboard, and a selection of additional equipment.
- > It can be used by authorized persons only. User identification is performed by means of a Mifare proximity card and/or a PIN code.
- > A user-friendly menu in English guarantees easy operation. Commands on the display guide the user through the entire procedure.
- > The value of the deposited packet can be declared directly at the device.
- > Once an item is successfully deposited, a confirmation receipt for the user can be printed or recorded on the Mifare proximity card.
- > Event log.
- > Infrared barriers.
- > Emergency power supply.

## > Additional equipment:

- > Weather- and vandal-resistant door.
- > Drop chute.
- > Drum or chute lighting.
- > Printer.
- > B&W, color or HD camera.
- > Barcode reader.
- > Mifare proximity card reader.
- > Door can be adapted to enable connection to the access control system.
- > Access control system.
- > Certified locks: electronic or combination.
- > Remotely controlled locks.
- > Lock casing in outer doors.
- > One time code system.
- > Alarm sensors:
  - > Sensors of partial door closure;
  - > Sensor of bolts position in deposit compartment;
- > 'Fishing' sensor;
- > Overfill sensor;
- > Paper sensor in the printer.
- > Seismic sensor.
- > Alarm installation output.
- > Finishing frame.
- > Mounting anchors.



The product is individually configured and may visually differ from the one presented on the picture.

# Electronic Deposit Strong Safes grade II-VI

## > Innovative solutions:

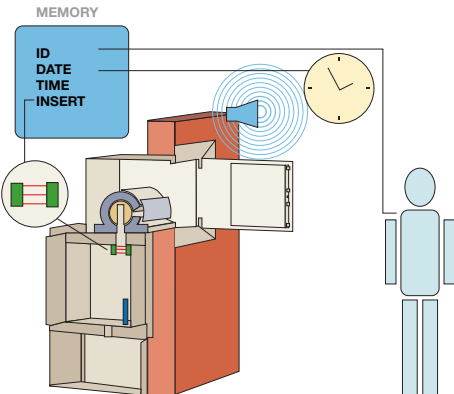

**A comprehensive event register** for as many as 10 thousand entries. Deposit dropping and receipt, and administrative maintenance of the device are all recorded in the register.

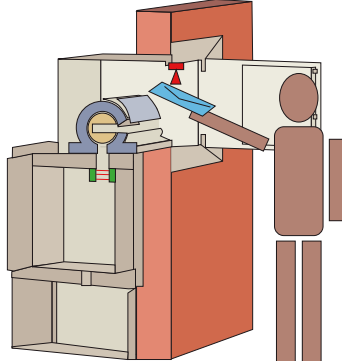

**Package identification using a barcode.** Code scanning or keyboard entry.

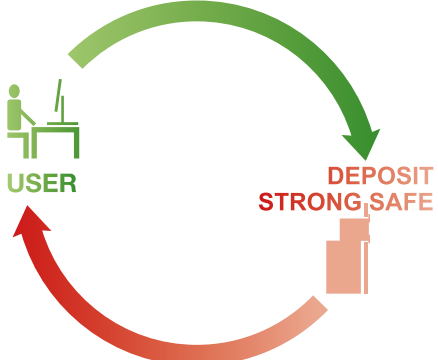

**Remote control.** The Deposit Strong Safe can be connected to a central bank application via Ethernet. This allows for remote controlling of all functions of the device.



**Electronic confirmation of deposit insertion.** A patent-protected solution of recording the confirmation on the user's card instead of the traditional, printed paper confirmation receipt.

## ADVANCED SOLUTION

## WITH ONLINE BOOKING



### > Certificates for storing:

- > Valuables in accordance with the PN-EN 1143 standard, compliant with the grade of the deposit input unit (of the Safe).

### > Product description:

- > A solution aimed mainly at retail networks where cash is constantly handled.
- > Immediately after placing a deposit, the deposited values can be recorded on the bank account.
- > Online booking is possible thanks to an advanced computer system, which allows the integration of the banking system with Deposit Strong Safes.
- > The process can be individually and flexibly customized and adjusted to the requirements of the POS system.
- > The Deposit Safe with online booking comprises a mechanical part (deposit compartment and deposit drop drum) and an electronic part (electronic cassette):
  - > The mechanical part ensures safe and quick cash depositing.
  - > The electronic part enables communication between the electronic safe and the bank's IT system, as well as the customer's head office.

### > Standard equipment:

- > Base – a deposit device with a drop slot.
- > Scanner – for code scanning and optional user identification.
- > Display – guiding the user through the cash deposit process.
- > Keyboard – for entering the declared amount and/or logging in.
- > Infrared Barriers – informing the system of a placed deposit.
- > Anti-fishing (unauthorized deposit removal) system.

### > Additional equipment:

- > Event history register.
- > Remote authorization and current information about the operational status of the Deposit Strong Safe.
- > Remote lock and drop drum blockade management.
- > Remote maintenance and diagnostics.
- > Camera.
- > Printer.
- > Deposit compartment filling sensor.
- > Printer paper status.
- > Seismic sensor.
- > Alarm installation output.
- > Deposit drum illumination.
- > Remote control.

## FINANCIAL BENEFITS



Money is booked on the client's account immediately after the deposit is made



Real-time access to the deposited amount



Increased financial liquidity of the company



Improvement and automation of the cashier settlement process



Significant CIT cost reduction

# Electronic Deposit Strong Safes with Online Booking



## Security

- › Cash is stored safely.
- › User identification: PIN code or MIFARE card.
- › Package identification: safe envelope barcode scanning, POS barcode scanning or package number declaration.
- › Amount identification: keyboard entry, scanning of the POS printout or downloading relevant information from the POS management system.

## Information

- › Real-time, full information on the amount of cash collected in individual points of sales, integrated with the KONSMETAL Deposit Strong Safe system, and on the amount left at the cash register.
- › An event log of all the cash operations.
- › Possibility of generating online reports in any format (HTML, EXCEL, PDF).

## Convenience

- › Quick and easy way for the cashier to make cash register settlements and comfortably deposit the collected value.
- › Remote management of user permissions.
- › Remote diagnostics function.
- › Remote management of Deposit Strong Safes from a single or multiple workstations.

## Savings

- › Real-time access to deposited amounts.
- › Increasing the company's financial liquidity.
- › Reduction in CIT cost.
- › Cashier settlement process optimization.



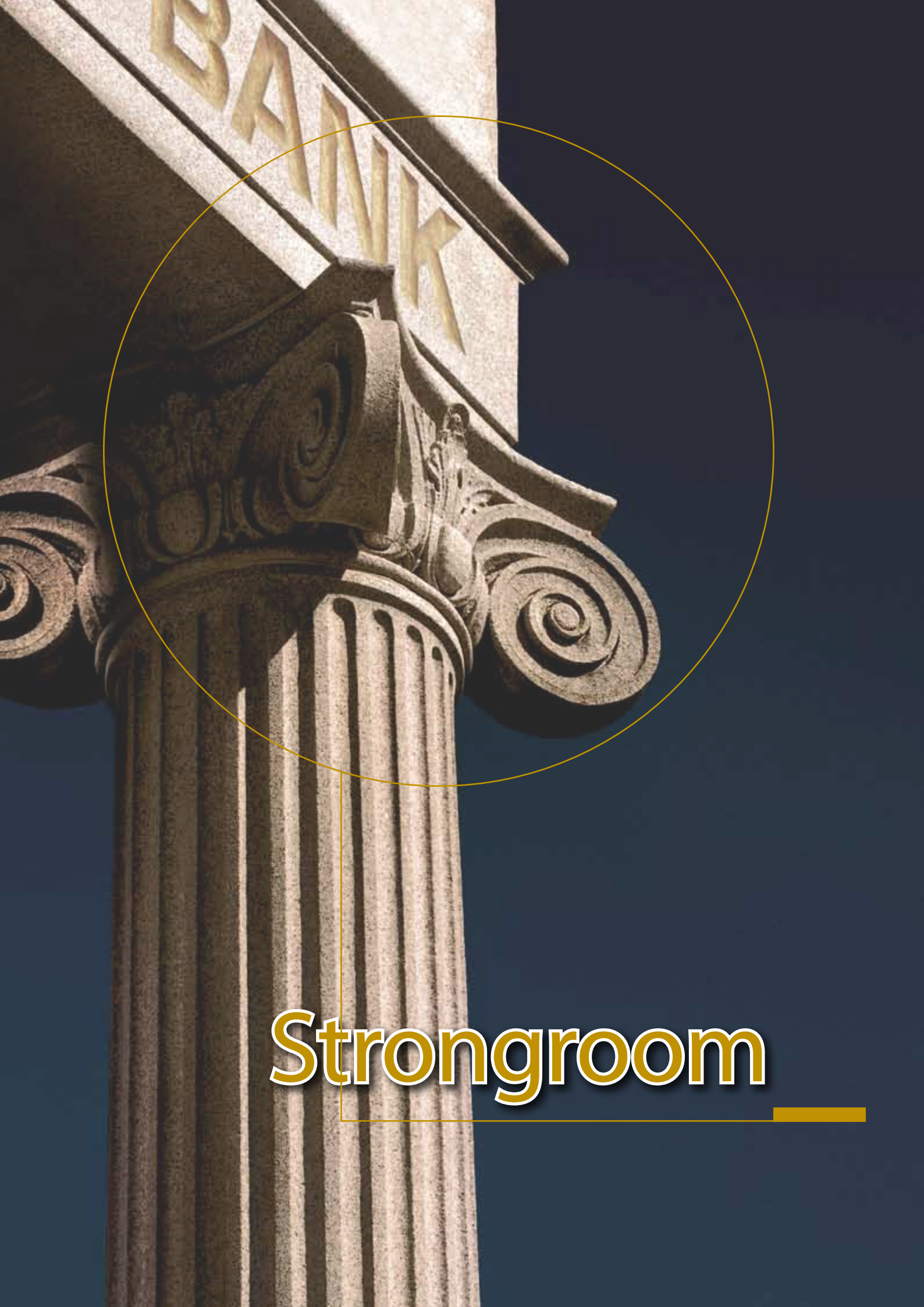

# Strongroom

---

# Strongroom grade V, VI, IX, XI

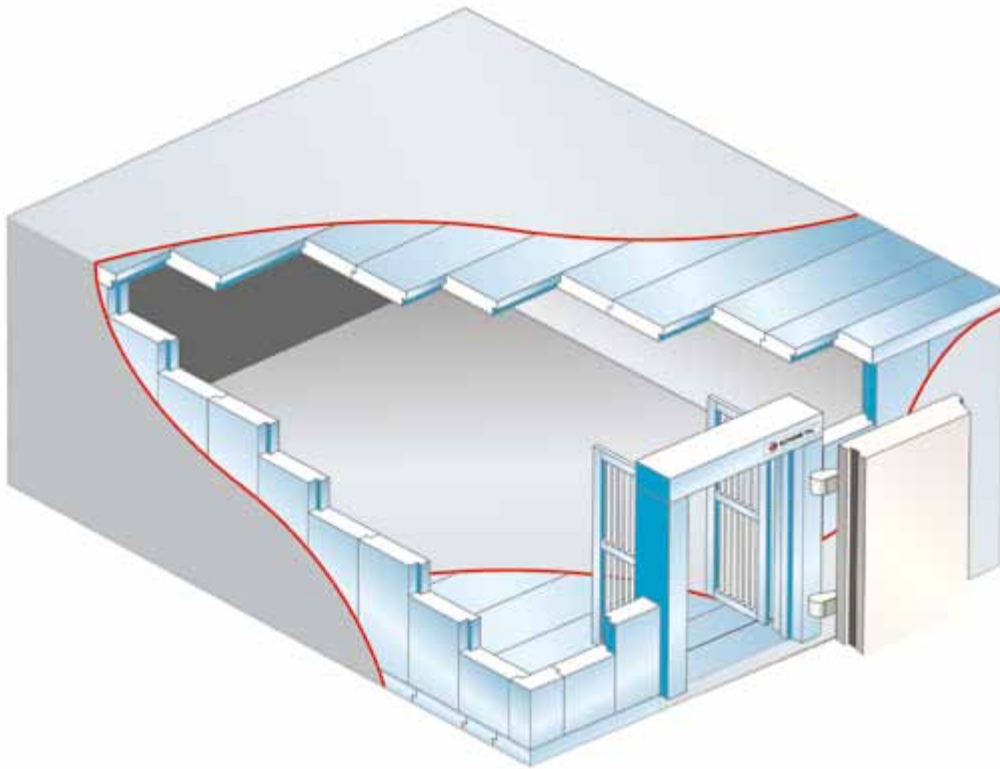

## Strongroom:

### > Certificates for storing:

- > Valuables in accordance with the PN-EN 1143-1+A1:2009 standard, grade V, VI, IX, XI.

### > Product description:

- > Special rooms designed for long-term storage of cash in banks and other financial institutions.
- > Built of special cast or modular panels enabling quick assembly and disassembly of the premises.
- > Existing Strongroom facilities can be provided with additional reinforcement and re-qualified to higher grades.
- > High burglary resistance with additional anti-burglary reinforcement.
- > Using special cast applied to Strongroom walls is certified by the Institute of Precision Mechanics in Warsaw, for grades V and VI.
- > Emergency hatch can be installed in the Strongroom walls (recommended).
- > Size can be customized to the user's needs.

## Strongroom doors:

### > Product description:

- > Installed in modular and cast Strongroom.
- > Filled with special steel reinforcement and a mixture of concrete with selected additives, suitable for specific protection grades.
- > From grade IX, equipped with a single or double gate (standard option).
- > Selection of the opening direction of the main door and gate.
- > Equipped with locks of the highest protection level.
- > Lock breaking and point attack protection (standard option).
- > Alarm installation output.
- > 24-month warranty.

### > Additional equipment:

- > Electronic lock.
- > Alarm sensors: shock, bolt and door position sensors.

Technical data - Strongroom

Model	Width of wall [mm]	Grade
SM 80/V	80	V
SM 80/VI	80	VI
SM 170/IX	150	IX
SM 220/XI	190	XI

Technical data - Strongroom doors

Door type	Width of armor [mm]	Grade
DSK 80/V	80	V
DSK 80/VI	80	VI
DSK 15/IX	150	IX
DSK 19/XI	190	XI

## DIAGRAM OF CASH FLOW IN AN ORGANIZATION

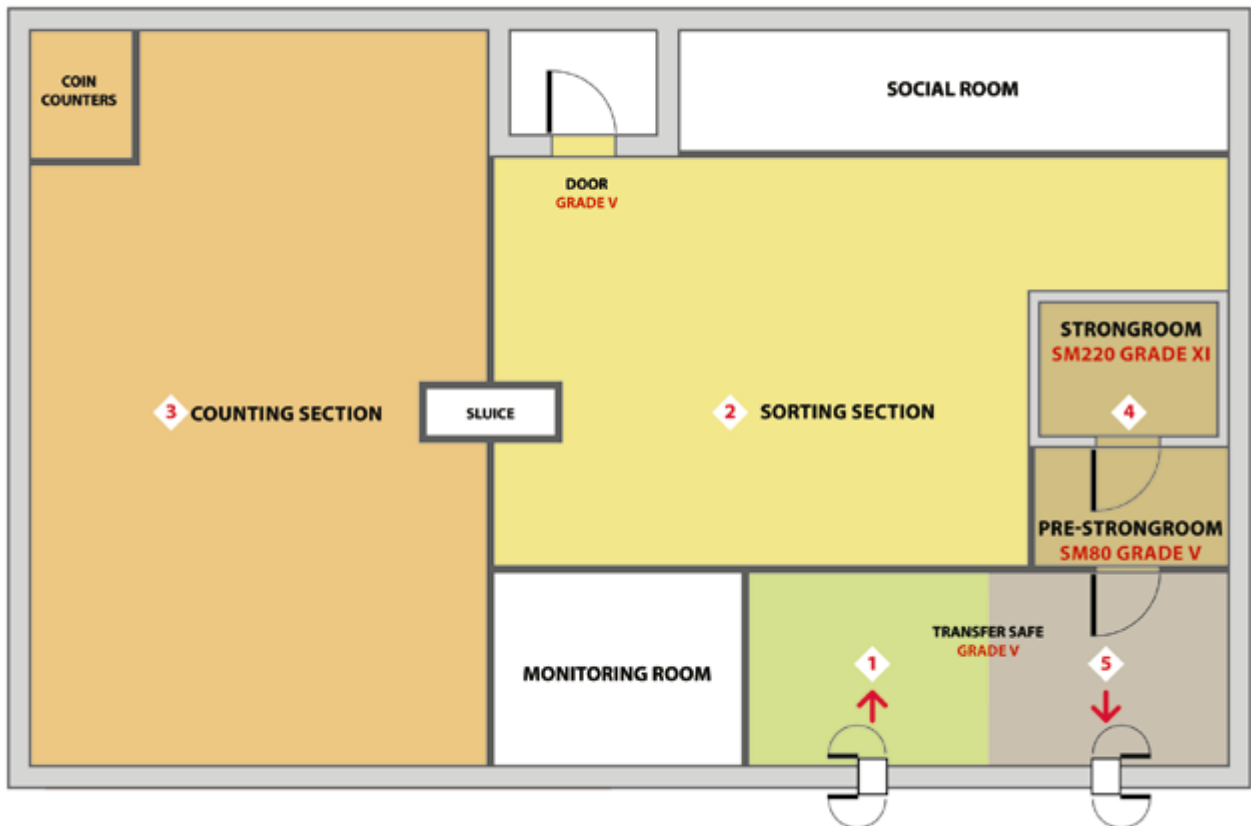

### > Certificates for storing:

- > Valuables in accordance with the PN-EN 1143-1 standard, grade V-VII, IX, XI-XIII.

### > Product description:

- > A group of special premises designed for banks and other financial institutions where large amount of cash is circulated.
- > Designed to ensure safety for cash handling services within an organization.
- > The group of premises comprises:
  - > A sorting station;
  - > A counting station;
  - > Pre-strongroom area;
  - > A strongroom.
- > Built of special cast or modular elements enabling quick assembly and disassembly of the facility.
- > Existing rooms can be adapted for the purposes of the cash handling center.

- > Size customization to meet individual requirements.

- > Existing strongroom facilities can be provided with additional reinforcement and re-qualified to higher grades.
- > High burglary resistance with additional anti-burglary reinforcement.
- > 24-month warranty.

### Diagram description:

1. Cash collection from CIT to CHC (Transfer Safe).
2. Cash sorting stations (special facility in grade V or VI).
3. Cash counting (special facility in grade V or VI).
4. Cash storage (strongroom).
5. Cash collection by CIT (Transfer Safe).



Locks

# HIGH SECURITY LOCKS IN ACCORDANCE WITH PN-EN 1300:2006 STANDARD



## Key locks- K

- > IMP, VdS, ECB Certificates.
- > Possibility of key combinations 25.000-1.000.000.
- > Two keys in the set.



## Mechanical combination locks – S

- > IMP, VdS, ECB Certificates.
- > Three- or four-wheels, giving a million or one hundred million possible combinations.
- > Possibility of simple changing the code by oneself.

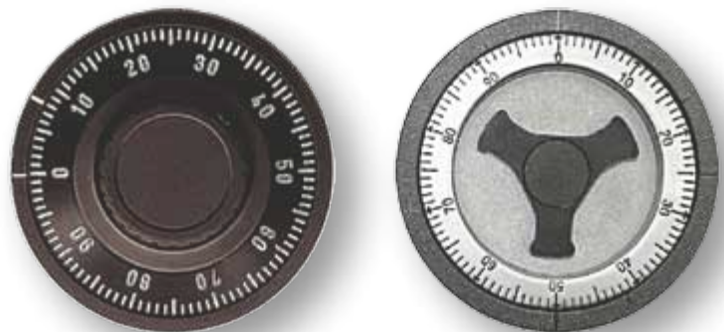

## Electronic locks – E

- > IMP, VdS, ECB Certificates.
- > Possibility of defining several users.
- > Time delay of the lock from 1 to 99 minutes.
- > Silent alarm if the lock.
- > Several minutes lock blockade after entering a wrong code.



An experienced thief can track down valuable objects on an area of 200m<sup>2</sup> in only 5 minutes.

A Safe is a mechanical security device that makes breaking in much more difficult than just an alarm system. It also protects our valuables in the period between the release of the alarm and the arrival of security guards.

People we let into our homes often constitute an underestimated hazard: babysitters, cleaners, renovation teams or our children's friends. Thieves take advantage of inattention or a temporary lack of supervision resulting from our trust.

A Safe ensures effective theft protection and discreetly secures our secrets from falling into the wrong hands. It also allows us to arrange valuable documents and to safeguard them against misplacing or theft.

In open-plan office spaces each of the employees has direct access to confidential documents or valuable objects of the office equipment.

A Safe may successfully replace standard office furniture and can be used as a container placed under a desk or a small cabinet for documents that require convenient access.









Companies, institutions and private apartments are constantly exposed to burglary and theft attempts.



### Worth to know



### All that is important stored in one place

-  passport, tickets, visas, driving license, credit cards
-  keys, access codes
-  unique documents in paper form, which may easily be destroyed or lost: notary deeds, agreements, policies, wills, diplomas, archives, etc.
-  data carriers (USB sticks, discs, spare discs, memory cards)
-  weapons and ammunition
-  coins, valuable collections
-  jewelry, precious metals and gemstones
-  cash, bonds
-  intellectual property: manuscripts, inventive designs, films, sketches

## > Determination of the safe localization

The Konsmetal product range consists of Safes intended for furniture or wall installation, as well as free standing devices, to be mounted directly on the floor.

Building a Safe into a wall reduces the impact on the room's interior – this is a convenient solution for carefully designed environments, where inconspicuous devices are most sought-after.

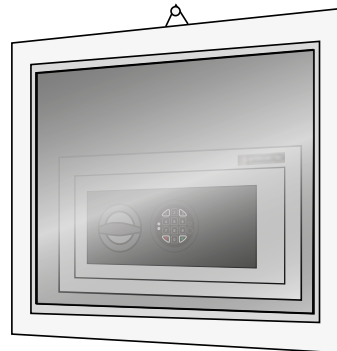

The Safe is hidden behind a painting or a mirror, ensuring secure and discrete storage of valuables.

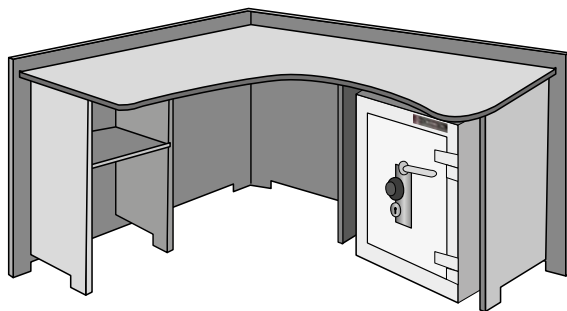

Furniture or free-standing Safes offer a wide range of options regarding the device's location and are suitable for applications where convenient access to the stored items is particularly required.

## > Type of item stored

In order to choose the Safe model that would suit your needs best, making a list of items to be stored is recommended. A different model of Safe is needed to store a notebook, weapons or a large number of document files.



## > Appropriate burglary resistance grade selection

An appropriate safety grade should be selected depending on the value of deposits to be stored. An adequate protection grade is also important when concluding an insurance contract.

### Burglar-proof protection level

burglar  
resistance  
grade

III

II

I

0

S2

S1

